

November 14, 2022

Conservation Commission  
Town of Ashland  
101 Main Street  
Ashland, Massachusetts 01721

Reference:

299 Wilson Street  
Ashland, Massachusetts  
EDC Job No.: 3595

Dear Commission Members:

In response to a peer review by GCG Associates, Inc., dated November 4, 2022, we are providing an attached response to comments in red.

Very truly yours,

ENGINEERING DESIGN CONSULTANTS, INC.

*Walter M. Lewinski*

Walter M. Lewinski, P.E.

## General Comments:

1. The project site at 299 Wilson Street is shown on the Town of Ashland Assessors record as 299 Howe Street (Map 17 parcel 0002), where consists of 2.76 acres, owned by the Town of Ashland Water Department and operating as their water treatment plant and pump station. The proposed riprap channels on the two sides the treatment plant driveway and the replacement of CMP pipe with a riprap/concrete channel are within parcel 0002. The Ashland Water Department also owns the southern abutting property as shown on the Hopkinton Assessors record as #0 Wilson Street, parcel R8 37 0, where consists of 3.097 acres in the Town of Hopkinton, where a water treatment lagoon is occupied. The proposed riprap settling basin is in parcel R8 37 0, where is under the Town of Hopkinton's jurisdiction, any work proposed within the Town of Hopkinton would require proper permits from the Town of Hopkinton and Hopkinton Conservation Commission's Order of Conditions.
2. The applicant should provide information regarding flagging of resource areas and a narrative report addressing project scope and goal, and how the project meets performance standards and stream standards.
3. The DEP comments should also be addressed which are attached as part of this letter.

## Plan Comments:

1. The proposed riprap at the up-stream (western) side of water treatment plant driveway should provide additional information which should include the following.
  - a. The southwest portion of the proposed riprap apron is in the Town of Hopkinton, work should coordinate with the Town of Hopkinton, applicant should identify the ownership of Wilson Street and obtain the proper permit(s) as necessary. **Wilson Street is wholly within Hopkinton until near the granite masonry culvert and we will process all work tasks with Hopkinton DPW and will limit the riprap settling basin limits within the boundary limits of the Town of Ashland property.**
  - b. Riprap apron dimensions (bottom width, channel depth and longitudinal slope) should be specified on the riprap apron detail plan. **Riprap channel dimension details have been added to the plans.**
  - c. Riprap apron section A-A shows an unspecified width channel bottom with 2H (horizontal) to 1V (vertical) side slope on two sides. GCG recommends providing additional existing contour(s) and spot grades in this area on the plan view. The existing twin 24-inch diameter RCPs (reinforced concrete pipe) culverts discharge onto this depression, where restricted by the twin 12-inch diameter VCPs (vitrified clay pipe) outlet underneath the paved driveway. Which creates backup/ponding situations in front of the twin 12" CV outlet pipes. Applicant should identify the existing overflow flow path during the backup occurrence. Plan should provide proposed contour to clarify if an

earth berm is required on the western side of the riprap apron, and analysis the overtop situations within the riprap apron/channel and control the overflow path. **The flow path for overflow is identified.**

- d. Riprap apron section A-A shows an elevation drop in front of the pipe(s) flared end section invert. Plan should provide riprap apron inverts. **Flared ends are not proposed, the riprap shall meet the existing pipe inverts.**
  - e. Clarify the intent of the flared end section(s), if proposed, which should be protected with riprap armor. If the deteriorated headwalls are intended to remain, they should be properly repaired. **Flared ends are not proposed, they were inadvertently left in the detail.**
2. The proposed riprap at the down-stream (eastern) side of water treatment plant driveway should provide additional information which should include the following.
    - a. Riprap apron dimensions, bottom width, height, invert, and slope should be shown on the plan. **The detail has been added to the plans.**
    - b. Discharge pipes end should be protected by flared end section with riprap armor or headwall. **Masonry headwalls will be reconstructed as needed.**
  3. Specify the location of the “Channel” section detail and provide dimensions, sizing channel bottom width to keep design flow within the armor section with freeboard or equipped with emergency spillway. **The plans have been revised and calculations are attached.**
  4. Existing 36” CMP (corrugated metal pipe) replacement should provide additional information which should include the following.
    - a. Identify the existing 3.5’W x 3’H box culvert lower invert elevation and analysis the maximum flow rate and velocity and sizing the concrete-riprap apron/channel accordingly, apron/channel dimensions, longitudinal slope, inverts should be specified on the plan. Channel should be sized to maintain the design flow within the armor section and sizing the downstream riprap apron width and length accordingly. **The invert is inaccessible, estimated invert elevation is 304.5. The channel design is based on the maximum flow the culvert will carry without overtopping the roadway. See attached calculations using NRCS based spreadsheet. The 36” CMP has a lower capacity than the 36” x 30” box culvert, so the less restrictive flow value was used.**
    - b. Identify the existing 18” AC (asbestos-cement) water main pipe elevations at the box culvert crossing, and analysis existing separation between the water main and box culvert. Provide details for the proposed concrete headwall. Headwall should be designed to encase the water main and box culvert including steel reinforcement should be installed around the water main encasement. Headwall on top of the water main is not acceptable. **A reinforced connection will be constructed at the terminus of the existing granite masonry culvert system before the exposed water main. The water main will be**

protected with a reinforced cast-in-place concrete collar along with the reinforced concrete lined channel. We would agree to final review of a Shop Drawing Details of the concrete and rebar specifications by Ashland DPW.

- c. Replacing the 36" CMP with concrete apron/channel will also reduce the pipe cover over the water main, evaluate the available space between bottom of the box culvert and water pipe to assure room for the proposed 24" thick stone/concrete slurry apron/channel. Water main with less than 4 feet of cover should be insulated. **The available cover over the water main will be less than 4-feet and we would again agree to final review of a Shop Drawing Details of the insulation detail by Ashland DPW.**
  - d. The existing concrete slab should be removed and disposed. Box Culvert end/outfall should be protected by a properly designed headwall. **This is properly noted on the Plan.**
5. The proposed settling basin is in the Town of Hopkinton and inside their 50 feet No Disturb Zone. Hopkinton Conservation Commission approval and waiver may be required. Additional issues should be addressed as follows.
- a. The proposed contour 312 connects to the contour inside the wetland area and the south end of the same contour connects to contour 314 and should be revised. The contours as shown will require grading in the wetland resource area. **The contour has been revised.**
  - b. The proposed spot grade 311.0 at the easterly settling basin edge will create a narrow reach along the existing contour 312 in the wetland area. GCG recommends designing the outlet as a board-created weir spillway and sizing the opening to handle the design flow with sufficient breadth width to prevent erosion. **The riprap was sized accordingly.**
  - c. The proposed settling basin appeared to collect a small section of Wilson Street pavement surface runoff along the proposed basin and the surface runoff from portion of the water treatment lagoon driveway, which majority is gravel drive except for 50'+/- length pavement near the Wilson Street intersection. The impervious area runoff entering this settling basin is relatively limited. GCG recommends establishing an operation and maintenance plan for the settling basin, as proposed, the riprap bottom would require hand removal of debris and weeds, and difficult to remove sediments. GCG recommends installing a concrete pad or loam and seed basin floor with a gravel access path to allow maintenance vehicle or utilize wheelbarrow to remove accumulated sediments. **We anticipate that flow volumes will exceed rates that would allow an earthen bottom to properly establish. The O&M for this settling basin will anticipate removing sediments and replacing riprap when sediment volume exceeds storage capacity.**
  - d. Settling basin should be properly sized, since the impervious watershed area is relatively small. The storage volume could be reduced to a more gradual slope instead of the proposed 2H:1V steep side slope. The steep slope is also located within four feet from the edge of pavement. A guard rail should be installed. **Slopes have been made more gradual to avoid need for a guardrail.**

6. The last page of the Notice of Intent package included a NRCS Rock Riprap Lined Waterway Design – Cut/Paste Plan, which shows an 8-foot-wide bottom channel with 2.5' depth and 18 feet top width. Applicant should clarify the applicant and location of this waterway design. **This detail has been replaced with the 36"x30" riprap downstream detail.**

# Culvert Report

## 24" Water treatment

## Culvert 2

<b>CULVERT</b>		<b>EMBANKMENT</b>	
Shape	= Circular	Top Width	= 24.00 ft
Inlet Edge	= Square Edge/ Hdwall	Top Elevation	= 308.50 ft
Material	= Concrete	Crest Length	= 30.00 ft
Manning's n	= 0.012	<b>DISCHARGE</b>	
Rise	= 24 in	Method	= Qmin to Qmax
Span	= 24 in	Q Min	= 30.00 cfs
Invert Elev. Down	= 303.55 ft	Q Max	= 60.00 cfs
Length	= 34.0 ft	Q Increment	= 5.00 cfs
Slope	= 0.020 ft/ft	<b>TAILWATER</b>	
Invert Elev. Up	= 304.22 ft	Tailwater Elevation	= Normal Depth
No. Barrels	= 2		
Plan Skew Angle	= 0 degrees		

### CALCULATION SAMPLE

Discharge			Velocity		Depth		HGL @ Hw/D = 2.16		
Total	Culvert	Over Top	Down	Up	Down	Up	Down	Up	Hw
(cfs)	(cfs)	(cfs)	(ft/s)	(ft/s)	(in)	(in)	(ft)	(ft)	(ft)
55.00	54.54	0.46	10.82	9.10	18.0	21.8	305.05	306.04	308.54

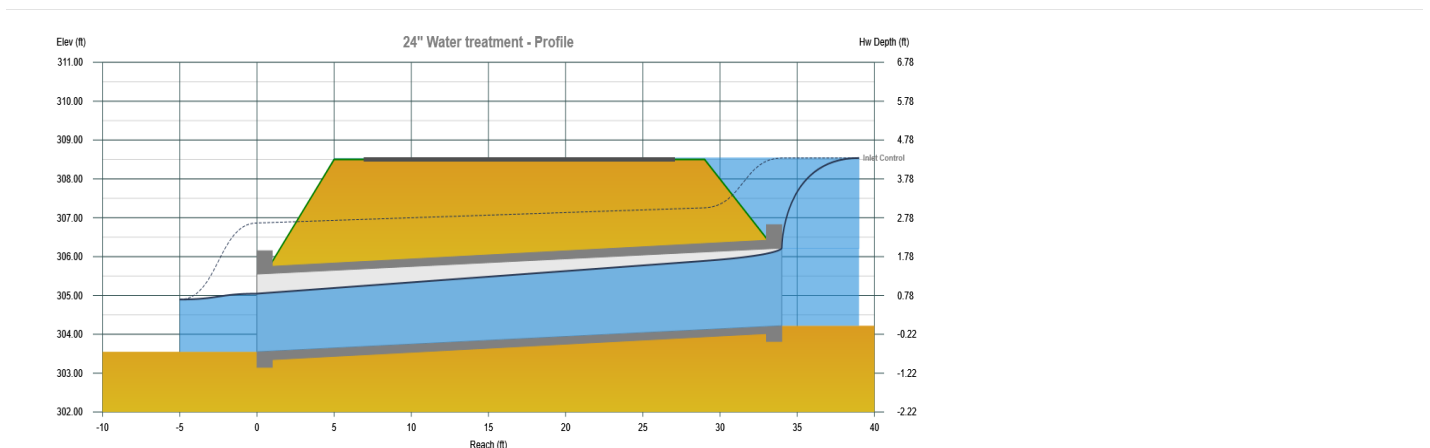

# Culvert Report

## 12" Water Treatment Plant

## Culvert 1

<b>CULVERT</b>		<b>EMBANKMENT</b>	
Shape	= Circular	Top Width	= 24.00 ft
Inlet Edge	= Projecting	Top Elevation	= 304.60 ft
Material	= Concrete	Crest Length	= 10.00 ft
Manning's n	= 0.012	<b>DISCHARGE</b>	
Rise	= 12 in	Method	= Qmin to Qmax
Span	= 12 in	Q Min	= 10.00 cfs
Invert Elev. Down	= 302.48 ft	Q Max	= 60.00 cfs
Length	= 28.0 ft	Q Increment	= 5.00 cfs
Slope	= 0.002 ft/ft	<b>TAILWATER</b>	
Invert Elev. Up	= 302.55 ft	Tailwater Elevation	= Normal Depth
No. Barrels	= 2		
Plan Skew Angle	= 0 degrees		

### CALCULATION SAMPLE

Discharge			Velocity		Depth		HGL @ Hw/D = 3.26		
Total	Culvert	Over Top	Down	Up	Down	Up	Down	Up	Hw
(cfs)	(cfs)	(cfs)	(ft/s)	(ft/s)	(in)	(in)	(ft)	(ft)	(ft)
55.00	14.15	40.85	9.01	9.01	12.0	12.0	303.48	304.42	305.81

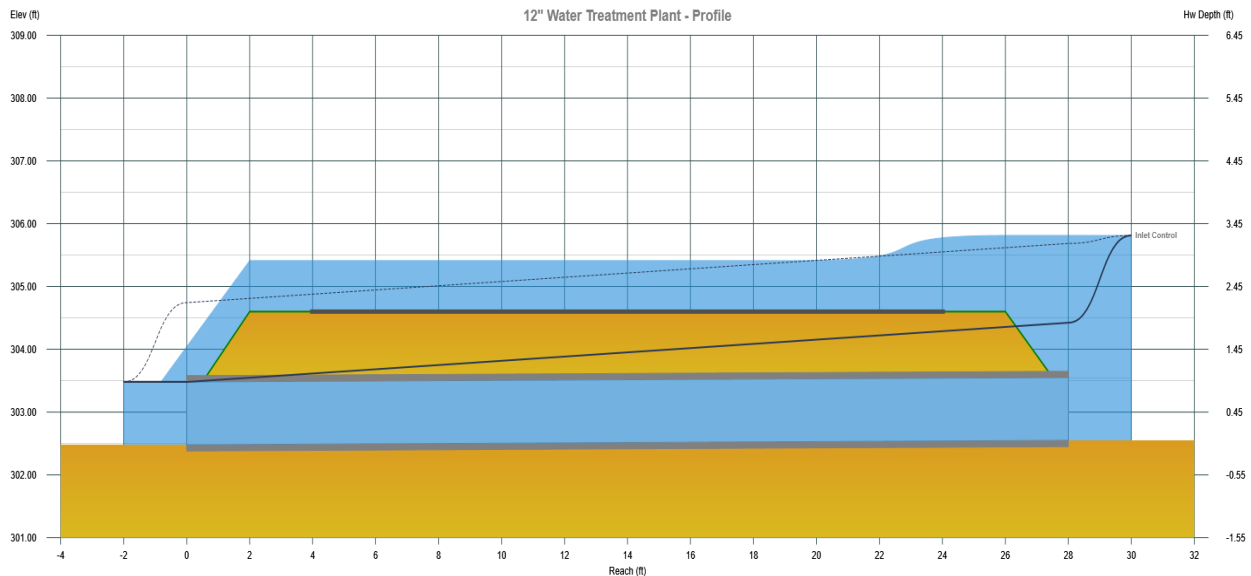

# Culvert Report

## 36X30 BOX

## Culvert 1

CULVERT		EMBANKMENT	
Shape	= Rectangular	Top Width	= 24.00 ft
Inlet Edge	= Projecting	Top Elevation	= Roadway Profile
Material	= Concrete	Crest Length	= Varied
Manning's n	= 0.012		
Rise	= 36 in	DISCHARGE	
Span	= 30 in	Method	= Qmin to Qmax
Invert Elev. Down	= 303.68 ft	Q Min	= 50.00 cfs
Length	= 78.0 ft	Q Max	= 95.00 cfs
Slope	= 0.046 ft/ft	Q Increment	= 2.00 cfs
Invert Elev. Up	= 307.26 ft		
No. Barrels	= 1	TAILWATER	
Plan Skew Angle	= 0 degrees	Tailwater Elevation	= Normal Depth

### CALCULATION SAMPLE

Discharge			Velocity		Depth		HGL @ Hw/D = 2.54		
Total	Culvert	Over Top	Down	Up	Down	Up	Down	Up	Hw
(cfs)	(cfs)	(cfs)	(ft/s)	(ft/s)	(in)	(in)	(ft)	(ft)	(ft)
88.00	88.00	0.00	17.87	11.73	23.6	36.0	305.65	310.26	314.88

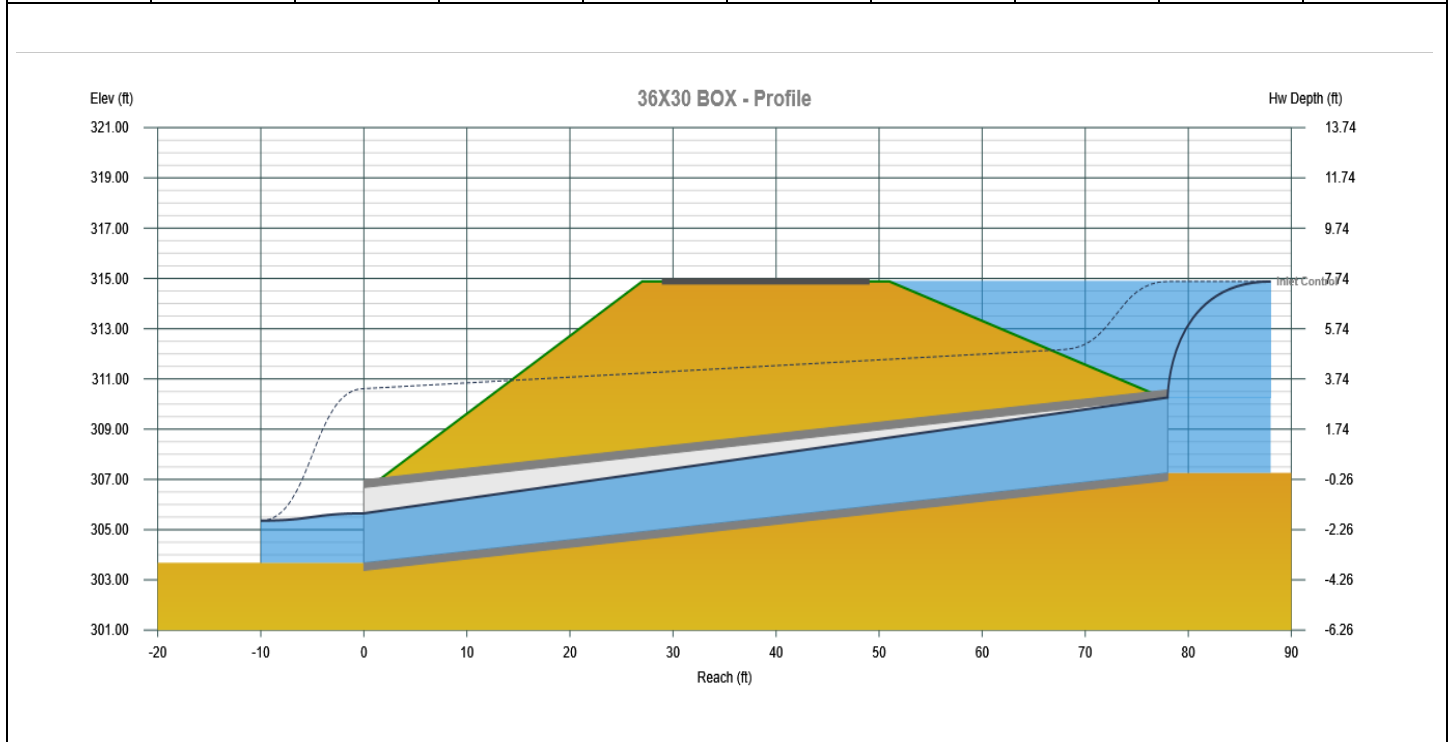

	A	B	C	D	E	F	G	H	I	
1	<b>Trapezoidal Riprap-Lined Waterway Design.xlsm</b>									
2	Landowner	24" Water Treatment	County	Middlesex			V 11.2019			
3	Computed By	WML	Date	11/8/2022			11/15/2019			
4	Checked by		Date							
5	<i>Note: Macros must be enabled in this spreadsheet in order for the "Solve" button to work.</i>									
6	Design flow, Q=	55	cfs			WW horiz. Length=	36.0	ft		
7	Slope, S=	0.0314	ft/ft =	31.85	:1	U/S WW F.L. elev=	303.7	ft		
8	Bottom Width, W=	7	ft			D/S WW F.L. elev=	302.5	ft		
9	Side slope, Z=	3	:1			Waterway drop=	1.1	ft		
10	Safety factor=	1.2		Typically 1.2		WW length along slope=	36.0	ft		
11	Rock shape =	Angular								
12	Min. req'd D50=	3.89	in			Spreadsheet formatting key:				
13	D50 used=	8.00	in			XXX	=Input cells			
14	n=	0.038				X.XX	=Output from "Solve" button			
15	Freeboard=	0.50	ft			X.XX	=Other computed output			
16						Red text	=Instructions, warnings, info			
17	Flow depth, d=	0.98	ft	Calculated						
18	Critical depth, d <sub>c</sub> =	1.06	ft							
19	Critical slope, S <sub>c</sub> =	0.024	ft/ft	0.7S <sub>c</sub> =	0.0166	ft/ft				
20				1.3S <sub>c</sub> =	0.0308	ft/ft				
21	Design slope, S=	0.0314	ft/ft	Design slope OK. Flow is Supercritical.						
22	Velocity=	5.63	fps			Est. riprap unit wt=	1.4	Tons/CY		
23				Rock shape =	Angular	Rock Gs =	2.65			
24	Riprap thickness:			Required riprap gradation for D50 selected						
25	Minimum=	1.33	ft	%	Rock dia., inches		Rock weight, lb			
26	Provided=	1.50	ft	Smaller	min.	max.	min.	max.		
27				100	12.0	16.0	126	298		
28	Sideslope height:			85	10.4	14.4	82	218		
29	Minimum=	1.48	ft	50	8.0	12.0	37	126		
30	Provided=	1.50	ft	10	6.4	10.4	19	82		
31										
32										
33										
34										
35										
36	Quantities:									
37	Riprap volume=	43.0	CY							
38	Approx. weight=	60.2	Tons							
39	Geotextile area=	155.8	SY*							
40										
41										
42	*Geotextile area									
43	includes actual covered									
44	surfaces only (no extra									
45	for laps or anchorage)									
46										

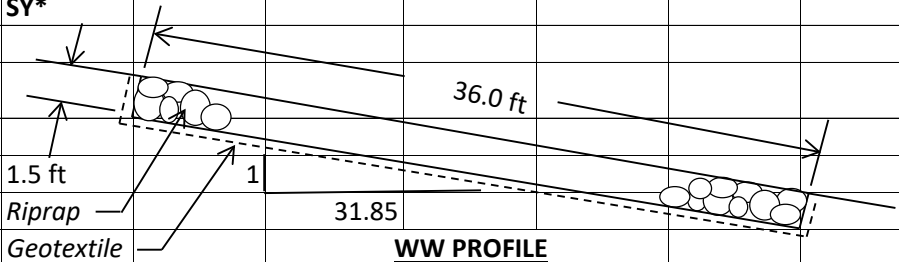
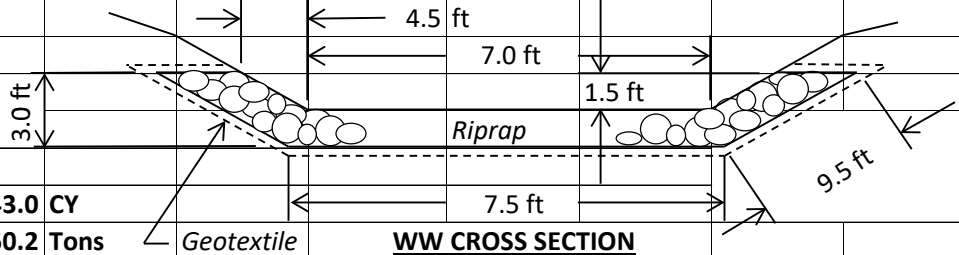

# Rock Riprap Lined Waterway Design - Cut/Paste Plan

(Version WI-July-2010, Based on Design of Rock Chutes by Robinson, Rice, Kadavy, ASAE, 1998)

Client 24" Water Treatment  
 Designer: WML  
 Date: 11/8/2022

County: Middlesex  
 Checked by: \_\_\_\_\_  
 Date: \_\_\_\_\_

**Design Values**

D<sub>50</sub> dia. = 8.0 in.  
 Rock<sub>ww</sub> thickness = 1.5 Feet.

**Rock Gradation Envelope**

<u>% Passing</u>	<u>Diameter, in. (weight, lbs.)</u>
D <sub>100</sub> -----	12 - 16 (122 - 290)
D <sub>85</sub> -----	10 - 14 (80 - 211)
D <sub>50</sub> -----	8 - 12 (36 - 122)
D <sub>10</sub> -----	6 - 10 (19 - 80)

Coefficient of Uniformity, (D<sub>60</sub>)/(D<sub>10</sub>) < 1.7

**Quantities**

Rock = 43 yd<sup>3</sup>  
 Geotextile (WCS-13)<sup>a</sup> = 156 yd<sup>2</sup>

**Notes:** <sup>a</sup> Geotextile Class I (Non-woven) shall be overlapped and anchored (18-in. minimum along sides and 24-in. minimum on the ends) --- quantity not included.

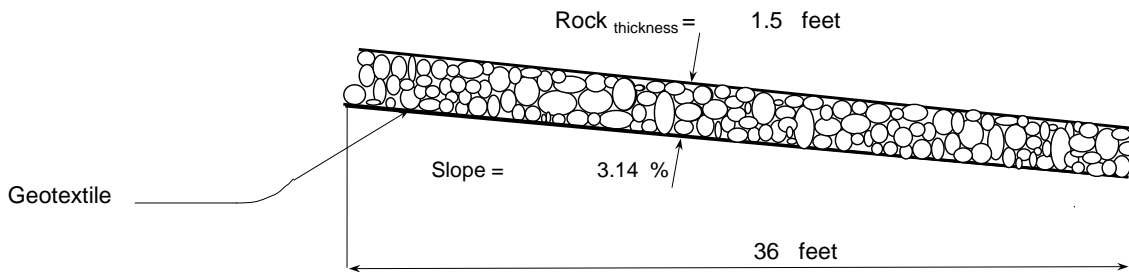

**Profile Along Centerline of Rock Lined Waterway**

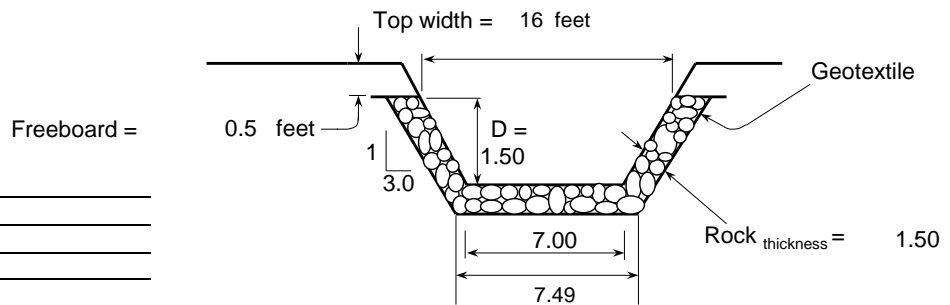

**Rock Lined WW Cross Section**

**Profile, Cross Sections, and Quantities**

Notes:  
 \_\_\_\_\_  
 \_\_\_\_\_  
 \_\_\_\_\_  
 \_\_\_\_\_  
 \_\_\_\_\_



	Date	File Name
Drawn	11/8/22	
Checked	1/0/00	
Approved		

Sheet \_\_\_ of \_\_\_

	A	B	C	D	E	F	G	H	I	
1	<b>Trapezoidal Riprap-Lined Waterway Design.xlsm</b>									
2	Landowner	12" Water Treatment	County	Middlesex			V 11.2019			
3	Computed By	WML	Date	11/8/2022			11/15/2019			
4	Checked by		Date							
5	<i>Note: Macros must be enabled in this spreadsheet in order for the "Solve" button to work.</i>									
6	Design flow, Q=	55	cfs			WW horiz. Length=	30.0	ft		
7	Slope, S=	0.083	ft/ft	=	12.05	:1	U/S WW F.L. elev=	302.5	ft	
8	Bottom Width, W=	7	ft			D/S WW F.L. elev=	300.0	ft		
9	Side slope, Z=	3	:1			Waterway drop=	2.5	ft		
10	Safety factor=	1.2		Typically 1.2		WW length along slope=	30.1	ft		
11	Rock shape =	Angular								
12	Min. req'd D50=	8.43	in			Spreadsheet formatting key:				
13	D50 used=	10.00	in			XXX	=Input cells			
14	n=	0.046				X.XX	=Output from "Solve" button			
15	Freeboard=	0.50	ft			X.XX	=Other computed output			
16						Red text	=Instructions, warnings, info			
17	Flow depth, d=	0.83	ft	Calculated						
18	Critical depth, d <sub>c</sub> =	1.06	ft							
19	Critical slope, S <sub>c</sub> =	0.034	ft/ft	0.7S <sub>c</sub> =	0.0236	ft/ft				
20				1.3S <sub>c</sub> =	0.0438	ft/ft				
21	Design slope, S=	0.0830	ft/ft	Design slope OK. Flow is Supercritical.						
22	Velocity=	6.99	fps			Est. riprap unit wt=	1.4	Tons/CY		
23				Rock shape =	Angular	Rock Gs =	2.65			
24	Riprap thickness:			Required riprap gradation for D50 selected						
25	Minimum=	1.67	ft	%	Rock dia., inches		Rock weight, lb			
26	Provided=	1.50	ft	Smaller	min.	max.	min.	max.		
27	<i>Select larger riprap thickness</i>			100	15.0	20.0	246	583		
28	Sideslope height:			85	13.0	18.0	160	425		
29	Minimum=	1.33	ft	50	10.0	15.0	73	246		
30	Provided=	1.50	ft	10	8.0	13.0	37	160		
31										
32										
33										
34										
35										
36	Quantities:									
37	Riprap volume=	35.9	CY							
38	Approx. weight=	50.3	Tons							
39	Geotextile area=	132.2	SY*							
40										
41										
42	*Geotextile area									
43	includes actual covered									
44	surfaces only (no extra									
45	for laps or anchorage)									
46										

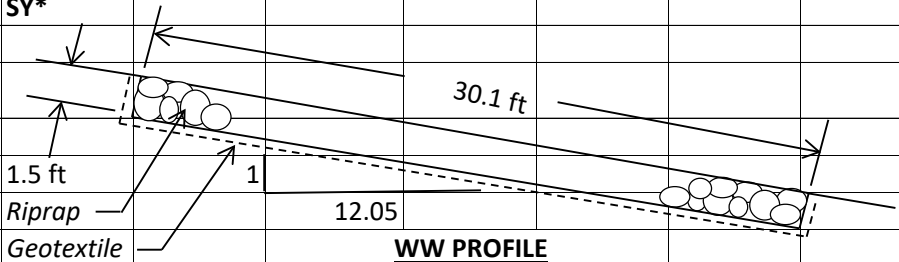
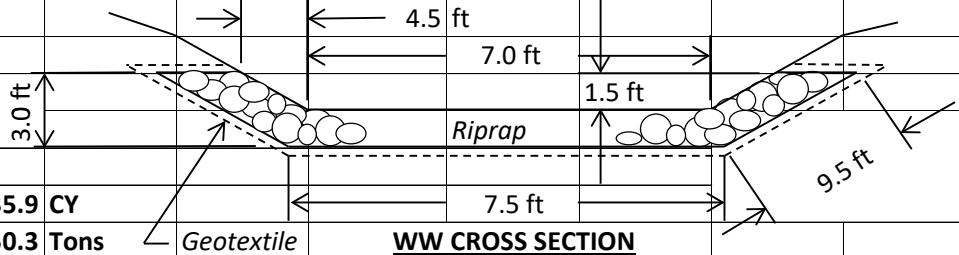

# Rock Riprap Lined Waterway Design - Cut/Paste Plan

(Version WI-July-2010, Based on Design of Rock Chutes by Robinson, Rice, Kadavy, ASAE, 1998)

Client: 12" Water Treatment  
 Designer: WML  
 Date: 11/8/2022

County: Middlesex  
 Checked by: \_\_\_\_\_  
 Date: \_\_\_\_\_

**Design Values**

D<sub>50</sub> dia. = 10.0 in.  
 Rock<sub>ww</sub> thickness = 1.5 Feet.

**Rock Gradation Envelope**

% Passing	Diameter, in. (weight, lbs.)
D <sub>100</sub> -----	15 - 20 (239 - 566)
D <sub>85</sub> -----	13 - 18 (155 - 413)
D <sub>50</sub> -----	10 - 15 (71 - 239)
D <sub>10</sub> -----	8 - 13 (36 - 155)

Coefficient of Uniformity, (D<sub>60</sub>)/(D<sub>10</sub>) < 1.7

**Quantities**

Rock = 36 yd<sup>3</sup>  
 Geotextile (WCS-13)<sup>a</sup> = 132 yd<sup>2</sup>

**Notes:** <sup>a</sup> Geotextile Class I (Non-woven) shall be overlapped and anchored (18-in. minimum along sides and 24-in. minimum on the ends) --- quantity not included.

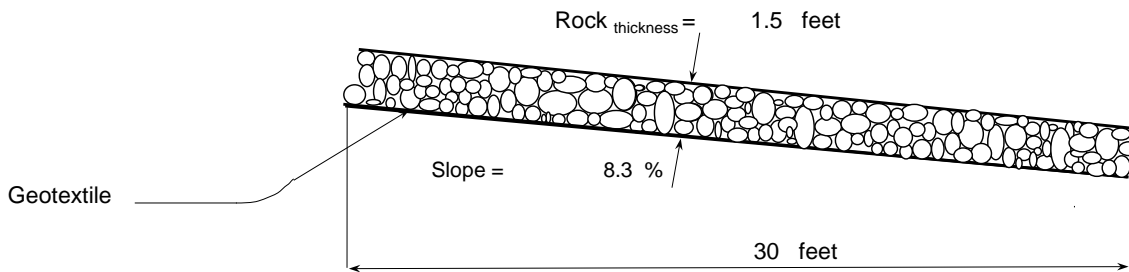

**Profile Along Centerline of Rock Lined Waterway**

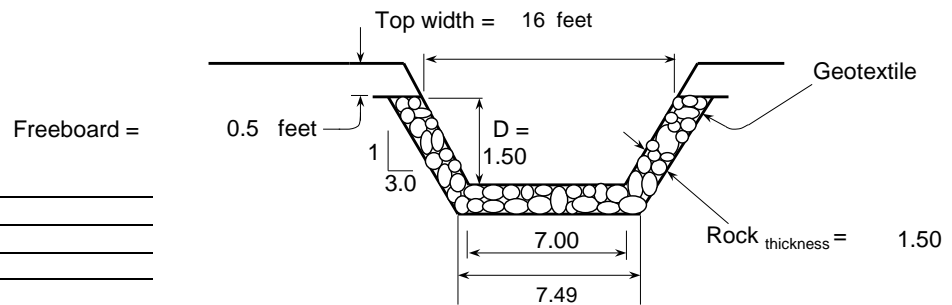

**Rock Lined WW Cross Section**

**Profile, Cross Sections, and Quantities**

Notes:  
 \_\_\_\_\_  
 \_\_\_\_\_  
 \_\_\_\_\_  
 \_\_\_\_\_  
 \_\_\_\_\_



	Date	File Name
Drawn	11/8/22	
Checked	11/0/00	
Approved		

Sheet \_\_\_ of \_\_\_

	A	B	C	D	E	F	G	H	I	
1	<b>Trapezoidal Riprap-Lined Waterway Design.xlsm</b>									
2	Landowner	36x30 Box		County	Middlesex			V 11.2019		
3	Computed By	WML		Date	11/8/2022			11/15/2019		
4	Checked by			Date						
5	<i>Note: Macros must be enabled in this spreadsheet in order for the "Solve" button to work.</i>									
6	Design flow, Q=	88	cfs			WW horiz. Length=	32.0	ft		
7	Slope, S=	0.13	ft/ft =	7.69	:1	U/S WW F.L. elev=	304.5	ft		
8	Bottom Width, W=	5.5	ft			D/S WW F.L. elev=	300.3	ft		
9	Side slope, Z=	2	:1			Waterway drop=	4.2	ft		
10	Safety factor=	1.2		Typically 1.2		WW length along slope=	32.3	ft		
11	Rock shape =	Angular								
12	Min. req'd D50=	15.49	in			Spreadsheet formatting key:				
13	D50 used=	16.00	in			XXX	=Input cells			
14	n=	0.052				X.XX	=Output from "Solve" button			
15	Freeboard=	0.50	ft			X.XX	=Other computed output			
16						Red text	=Instructions, warnings, info			
17	Flow depth, d=	1.19	ft	Calculated						
18	Critical depth, d <sub>c</sub> =	1.63	ft							
19	Critical slope, S <sub>c</sub> =	0.041	ft/ft	0.7S <sub>c</sub> =	0.0285	ft/ft				
20				1.3S <sub>c</sub> =	0.0530	ft/ft				
21	Design slope, S=	0.1300	ft/ft	Design slope OK. Flow is Supercritical.						
22	Velocity=	9.35	fps			Est. riprap unit wt=	1.4	Tons/CY		
23				Rock shape =	Angular	Rock Gs =	2.65			
24	Riprap thickness:			Required riprap gradation for D50 selected						
25	Minimum=	2.67	ft	%	Rock dia., inches		Rock weight, lb			
26	Provided=	3.00	ft	Smaller	min.	max.	min.	max.		
27				100	24.0	32.0	1007	2388		
28	Sideslope height:			85	20.8	28.8	656	1741		
29	Minimum=	1.69	ft	50	16.0	24.0	298	1007		
30	Provided=	2.00	ft	10	12.8	20.8	153	656		
31										
32										
33										
34										
35										
36	Quantities:									
37	Riprap volume=	78.4	CY							
38	Approx. weight=	109.7	Tons							
39	Geotextile area=	181.5	SY*							
40										
41										
42	*Geotextile area									
43	includes actual covered									
44	surfaces only (no extra									
45	for laps or anchorage)									
46										

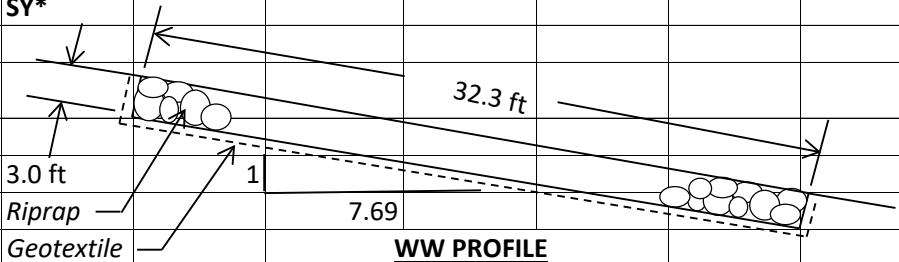
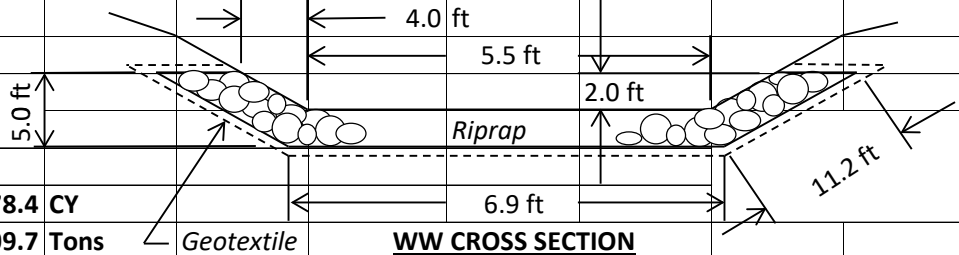

# Rock Riprap Lined Waterway Design - Cut/Paste Plan

(Version WI-July-2010, Based on Design of Rock Chutes by Robinson, Rice, Kadavy, ASAE, 1998)

Client 36x30 Box  
 Designer: WML  
 Date: 11/8/2022

County: Middlesex  
 Checked by: \_\_\_\_\_  
 Date: \_\_\_\_\_

**Design Values**

D<sub>50</sub> dia. = 16.0 in.  
 Rock<sub>ww</sub> thickness = 3.0 Feet.

**Rock Gradation Envelope**

<u>% Passing</u>	<u>Diameter, in. (weight, lbs.)</u>
D <sub>100</sub> -----	24 - 32 (978 - 2319)
D <sub>85</sub> -----	21 - 29 (637 - 1691)
D <sub>50</sub> -----	16 - 24 (290 - 978)
D <sub>10</sub> -----	13 - 21 (148 - 637)

Coefficient of Uniformity, (D<sub>60</sub>)/(D<sub>10</sub>) < 1.7

**Quantities**

Rock = 78 yd<sup>3</sup>  
 Geotextile (WCS-13)<sup>a</sup> = 182 yd<sup>2</sup>

**Notes:** <sup>a</sup> Geotextile Class I (Non-woven) shall be overlapped and anchored (18-in. minimum along sides and 24-in. minimum on the ends) --- quantity not included.

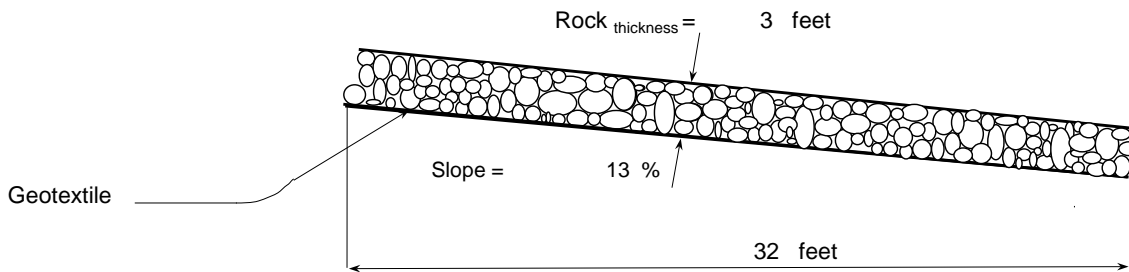

**Profile Along Centerline of Rock Lined Waterway**

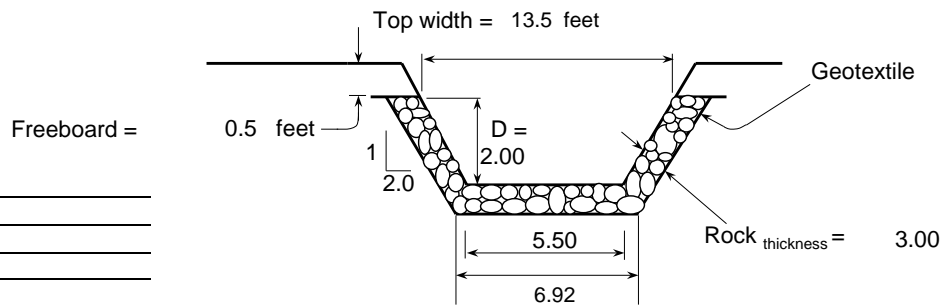

**Rock Lined WW Cross Section**

**Profile, Cross Sections, and Quantities**

Notes:  
 \_\_\_\_\_  
 \_\_\_\_\_  
 \_\_\_\_\_  
 \_\_\_\_\_  
 \_\_\_\_\_



	Date	File Name
Drawn	11/8/22	
Checked	1/0/00	
Approved		

Sheet \_\_\_ of \_\_\_