

Massachusetts Department of Environmental Protection
 Bureau of Resource Protection - Wetlands
WPA Form 3 – Notice of Intent
 Massachusetts Wetlands Protection Act M.G.L. c. 131, §40

Provided by MassDEP:

MassDEP File Number
Document Transaction Number
Ashland
City/Town

Important:
 When filling out forms on the computer, use only the tab key to move your cursor - do not use the return key.

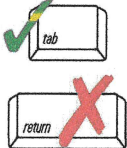

Note:
 Before completing this form consult your local Conservation Commission regarding any municipal bylaw or ordinance.

A. General Information

1. Project Location (**Note:** electronic filers will click on button to locate project site):

<u>27 Laurelton Drive</u>	<u>Ashland</u>	<u>01721</u>
a. Street Address	b. City/Town	c. Zip Code
Latitude and Longitude:	<u>42.23844</u>	<u>-71.48260</u>
	d. Latitude	e. Longitude
<u>0230</u>	<u>0182</u>	
f. Assessors Map/Plat Number	g. Parcel /Lot Number	

2. Applicant:

<u>Paul & Barbara</u>	<u>Todaro</u>	
a. First Name	b. Last Name	
c. Organization		
<u>27 Laurelton Drive</u>		
d. Street Address		
<u>Ashland</u>	<u>MA</u>	<u>01721</u>
e. City/Town	f. State	g. Zip Code
<u>(508) 397-4518</u>	<u>bltodaro10@gmail.com</u>	
h. Phone Number	i. Fax Number	j. Email Address

3. Property owner (required if different from applicant): Check if more than one owner

(Same as above)

<u></u>	<u></u>	
a. First Name	b. Last Name	
c. Organization		
<u></u>		
d. Street Address		
<u></u>	<u></u>	<u></u>
e. City/Town	f. State	g. Zip Code
<u></u>	<u></u>	<u></u>
h. Phone Number	i. Fax Number	j. Email address

4. Representative (if any):

<u>Glenn</u>	<u>Krevosky</u>	
a. First Name	b. Last Name	
<u>EBT Environmental Consultants, Inc.</u>		
c. Company		
<u>601 Main Street</u>		
d. Street Address		
<u>North Oxford</u>	<u>MA</u>	<u>01537</u>
e. City/Town	f. State	g. Zip Code
<u>(508) 769-3659</u>	<u>glenn.krevosky@charter.net</u>	
h. Phone Number	i. Fax Number	j. Email address

5. Total WPA Fee Paid (from NOI Wetland Fee Transmittal Form):

<u>\$110.00 (\$310.00 bylaw)</u>	<u>\$42.50</u>	<u>\$67.50 (\$310.00 bylaw)</u>
a. Total Fee Paid	b. State Fee Paid	c. City/Town Fee Paid

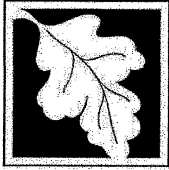

Massachusetts Department of Environmental Protection
Bureau of Resource Protection - Wetlands

WPA Form 3 – Notice of Intent

Massachusetts Wetlands Protection Act M.G.L. c. 131, §40

Provided by MassDEP:

MassDEP File Number

Document Transaction Number

Ashland

City/Town

A. General Information (continued)

6. General Project Description:

See attached A.6. General Project Description

7a. Project Type Checklist: (Limited Project Types see Section A. 7b.)

- | | |
|---|---|
| 1. <input type="checkbox"/> Single Family Home | 2. <input type="checkbox"/> Residential Subdivision |
| 3. <input type="checkbox"/> Commercial/Industrial | 4. <input type="checkbox"/> Dock/Pier |
| 5. <input type="checkbox"/> Utilities | 6. <input type="checkbox"/> Coastal engineering Structure |
| 7. <input type="checkbox"/> Agriculture (e.g., cranberries, forestry) | 8. <input type="checkbox"/> Transportation |
| 9. <input checked="" type="checkbox"/> Other | |

7b. Is any portion of the proposed activity eligible to be treated as a limited project (including Ecological Restoration Limited Project) subject to 310 CMR 10.24 (coastal) or 310 CMR 10.53 (inland)?

1. Yes No If yes, describe which limited project applies to this project. (See 310 CMR 10.24 and 10.53 for a complete list and description of limited project types)

2. Limited Project Type

If the proposed activity is eligible to be treated as an Ecological Restoration Limited Project (310 CMR10.24(8), 310 CMR 10.53(4)), complete and attach Appendix A: Ecological Restoration Limited Project Checklist and Signed Certification.

8. Property recorded at the Registry of Deeds for:

Middlesex South

a. County

19536

c. Book

b. Certificate # (if registered land)

483

d. Page Number

B. Buffer Zone & Resource Area Impacts (temporary & permanent)

- Buffer Zone Only – Check if the project is located only in the Buffer Zone of a Bordering Vegetated Wetland, Inland Bank, or Coastal Resource Area.
- Inland Resource Areas (see 310 CMR 10.54-10.58; if not applicable, go to Section B.3, Coastal Resource Areas).

Check all that apply below. Attach narrative and any supporting documentation describing how the project will meet all performance standards for each of the resource areas altered, including standards requiring consideration of alternative project design or location.

A.6. General Project Description

Site: 27 Laurelton Drive, Ashland

Applicant: Paul & Barbara Todaro

The applicant proposes to construct a 24' by 28' garage within the 100-foot buffer zone and ±79 square feet of which is within the 25' bylaw no disturb zone to a bordering vegetated wetland. The applicant is requesting a waiver, per Section 348-3D of the Ashland Wetland Regulation. The area where the garage is proposed is existing lawn for a house which was constructed in 1954. As mitigation for the portion of the garage in the 25' bylaw no disturb zone the application proposes to plant 2 areas (±176 square foot Area 1 and ±180 square foot Area 2) to the east of the property (see attached plan for planting locations and planting schedule).

Glenn E. Krevosky of EBT Environmental Consultants, Inc. delineated the wetland boundaries in August 2025 with 6 A series wetland flags - utilizing soils, vegetation and indicators of hydrology according to 310 CMR 10.55 (2) (c).

The erosion control measures of staked 9" straw wattles backed by entrenched silt fence, shown on the site plan, shall be placed prior to site work. These measures shall be maintained in good working order throughout the project until all exposed soils are final graded, loamed, seeded and stabilized with well-established soil stabilizing vegetation.

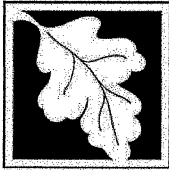

Massachusetts Department of Environmental Protection
Bureau of Resource Protection - Wetlands

WPA Form 3 – Notice of Intent

Massachusetts Wetlands Protection Act M.G.L. c. 131, §40

Provided by MassDEP:

MassDEP File Number

Document Transaction Number

Ashland

City/Town

B. Buffer Zone & Resource Area Impacts (temporary & permanent) (cont'd)

For all projects affecting other Resource Areas, please attach a narrative explaining how the resource area was delineated.

<u>Resource Area</u>	<u>Size of Proposed Alteration</u>	<u>Proposed Replacement (if any)</u>
a. <input type="checkbox"/> Bank	1. linear feet _____	2. linear feet _____
b. <input type="checkbox"/> Bordering Vegetated Wetland	1. square feet _____	2. square feet _____
c. <input type="checkbox"/> Land Under Waterbodies and Waterways	1. square feet _____ 3. cubic yards dredged _____	2. square feet _____

<u>Resource Area</u>	<u>Size of Proposed Alteration</u>	<u>Proposed Replacement (if any)</u>
d. <input type="checkbox"/> Bordering Land Subject to Flooding	1. square feet _____ 3. cubic feet of flood storage lost _____	2. square feet _____ 4. cubic feet replaced _____
e. <input type="checkbox"/> Isolated Land Subject to Flooding	1. square feet _____ 2. cubic feet of flood storage lost _____	3. cubic feet replaced _____
f. <input type="checkbox"/> Riverfront Area	1. Name of Waterway (if available) - specify coastal or inland _____	

2. Width of Riverfront Area (check one):

- 25 ft. - Designated Densely Developed Areas only
- 100 ft. - New agricultural projects only
- 200 ft. - All other projects

3. Total area of Riverfront Area on the site of the proposed project: _____ square feet

4. Proposed alteration of the Riverfront Area:

a. total square feet _____ b. square feet within 100 ft. _____ c. square feet between 100 ft. and 200 ft. _____

5. Has an alternatives analysis been done and is it attached to this NOI? Yes No

6. Was the lot where the activity is proposed created prior to August 1, 1996? Yes No

3. Coastal Resource Areas: (See 310 CMR 10.25-10.35)

Note: for coastal riverfront areas, please complete **Section B.2.f.** above.

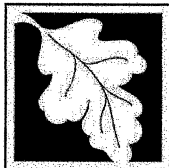

Massachusetts Department of Environmental Protection
Bureau of Resource Protection - Wetlands

WPA Form 3 – Notice of Intent

Massachusetts Wetlands Protection Act M.G.L. c. 131, §40

Provided by MassDEP:
MassDEP File Number
Document Transaction Number
Ashland
City/Town

B. Buffer Zone & Resource Area Impacts (temporary & permanent) (cont'd)

Check all that apply below. Attach narrative and supporting documentation describing how the project will meet all performance standards for each of the resource areas altered, including standards requiring consideration of alternative project design or location.

Online Users:
Include your document transaction number (provided on your receipt page) with all supplementary information you submit to the Department.

<u>Resource Area</u>	<u>Size of Proposed Alteration</u>	<u>Proposed Replacement (if any)</u>
a. <input type="checkbox"/> Designated Port Areas	Indicate size under Land Under the Ocean, below	
b. <input type="checkbox"/> Land Under the Ocean	_____	
	1. square feet	

	2. cubic yards dredged	
c. <input type="checkbox"/> Barrier Beach	Indicate size under Coastal Beaches and/or Coastal Dunes below	
d. <input type="checkbox"/> Coastal Beaches	_____	_____
	1. square feet	2. cubic yards beach nourishment
e. <input type="checkbox"/> Coastal Dunes	_____	_____
	1. square feet	2. cubic yards dune nourishment
	<u>Size of Proposed Alteration</u>	<u>Proposed Replacement (if any)</u>
f. <input type="checkbox"/> Coastal Banks	_____	
	1. linear feet	
g. <input type="checkbox"/> Rocky Intertidal Shores	_____	
	1. square feet	
h. <input type="checkbox"/> Salt Marshes	_____	_____
	1. square feet	2. sq ft restoration, rehab., creation
i. <input type="checkbox"/> Land Under Salt Ponds	_____	
	1. square feet	

	2. cubic yards dredged	
j. <input type="checkbox"/> Land Containing Shellfish	_____	
	1. square feet	
k. <input type="checkbox"/> Fish Runs	Indicate size under Coastal Banks, inland Bank, Land Under the Ocean, and/or inland Land Under Waterbodies and Waterways, above	

	1. cubic yards dredged	
l. <input type="checkbox"/> Land Subject to Coastal Storm Flowage	_____	
	1. square feet	

4. Restoration/Enhancement
If the project is for the purpose of restoring or enhancing a wetland resource area in addition to the square footage that has been entered in Section B.2.b or B.3.h above, please enter the additional amount here.

_____	_____
a. square feet of BVW	b. square feet of Salt Marsh

5. Project Involves Stream Crossings

_____	_____
a. number of new stream crossings	b. number of replacement stream crossings

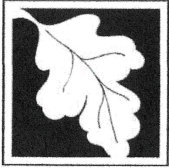

Massachusetts Department of Environmental Protection
 Bureau of Resource Protection - Wetlands
WPA Form 3 – Notice of Intent
 Massachusetts Wetlands Protection Act M.G.L. c. 131, §40

Provided by MassDEP:

MassDEP File Number

Document Transaction Number

Ashland

City/Town

C. Other Applicable Standards and Requirements

This is a proposal for an Ecological Restoration Limited Project. Skip Section C and complete Appendix A: Ecological Restoration Limited Project Checklists – Required Actions (310 CMR 10.11).

Streamlined Massachusetts Endangered Species Act/Wetlands Protection Act Review

1. Is any portion of the proposed project located in **Estimated Habitat of Rare Wildlife** as indicated on the most recent Estimated Habitat Map of State-Listed Rare Wetland Wildlife published by the Natural Heritage and Endangered Species Program (NHESP)? To view habitat maps, see the *Massachusetts Natural Heritage Atlas* or go to http://maps.massgis.state.ma.us/PRI_EST_HAB/viewer.htm.

a. Yes No **If yes, include proof of mailing or hand delivery of NOI to:**

Current
 MassMapper _____

Natural Heritage and Endangered Species Program
Division of Fisheries and Wildlife
 1 Rabbit Hill Road
 Westborough, MA 01581

If yes, the project is also subject to Massachusetts Endangered Species Act (MESA) review (321 CMR 10.18). To qualify for a streamlined, 30-day, MESA/Wetlands Protection Act review, please complete Section C.1.c, and include requested materials with this Notice of Intent (NOI); *OR* complete Section C.2.f, if applicable. *If MESA supplemental information is not included with the NOI, by completing Section 1 of this form, the NHESP will require a separate MESA filing which may take up to 90 days to review (unless noted exceptions in Section 2 apply, see below).*

c. Submit Supplemental Information for Endangered Species Review*

- 1. Percentage/acreage of property to be altered:
 - (a) within wetland Resource Area _____ percentage/acreage
 - (b) outside Resource Area _____ percentage/acreage

2. Assessor's Map or right-of-way plan of site

- 2. Project plans for entire project site, including wetland resource areas and areas outside of wetlands jurisdiction, showing existing and proposed conditions, existing and proposed tree/vegetation clearing line, and clearly demarcated limits of work **
 - (a) Project description (including description of impacts outside of wetland resource area & buffer zone)
 - (b) Photographs representative of the site

* Some projects **not** in Estimated Habitat may be located in Priority Habitat, and require NHESP review (see <https://www.mass.gov/endangered-species-act-mesa-regulatory-review>).

Priority Habitat includes habitat for state-listed plants and strictly upland species not protected by the Wetlands Protection Act.

** MESA projects may not be segmented (321 CMR 10.16). The applicant must disclose full development plans even if such plans are not required as part of the Notice of Intent process.



Massachusetts Department of Environmental Protection
Bureau of Resource Protection - Wetlands

WPA Form 3 – Notice of Intent

Massachusetts Wetlands Protection Act M.G.L. c. 131, §40

Provided by MassDEP:

MassDEP File Number

Document Transaction Number

Ashland

City/Town

C. Other Applicable Standards and Requirements (cont'd)

- (c) MESA filing fee (fee information available at <https://www.mass.gov/how-to/how-to-file-for-a-mesa-project-review>).

Make check payable to "Commonwealth of Massachusetts - NHESP" and **mail to NHESP** at above address

Projects altering 10 or more acres of land, also submit:

- (d) Vegetation cover type map of site

- (e) Project plans showing Priority & Estimated Habitat boundaries

- (f) OR Check One of the Following

1. Project is exempt from MESA review.
Attach applicant letter indicating which MESA exemption applies. (See 321 CMR 10.14, <https://www.mass.gov/service-details/exemptions-from-review-for-projectsactivities-in-priority-habitat>; the NOI must still be sent to NHESP if the project is within estimated habitat pursuant to 310 CMR 10.37 and 10.59.)

2. Separate MESA review ongoing.

a. NHESP Tracking #

b. Date submitted to NHESP

3. Separate MESA review completed.

Include copy of NHESP "no Take" determination or valid Conservation & Management Permit with approved plan.

3. For coastal projects only, is any portion of the proposed project located below the mean high water line or in a fish run?

- a. Not applicable – project is in inland resource area only b. Yes No

If yes, include proof of mailing, hand delivery, or electronic delivery of NOI to either:

South Shore - Bourne to Rhode Island border, and
the Cape & Islands:

North Shore - Plymouth to New Hampshire border:

Division of Marine Fisheries -
Southeast Marine Fisheries Station
Attn: Environmental Reviewer
836 South Rodney French Blvd.
New Bedford, MA 02744
Email: dmf.envreview-south@mass.gov

Division of Marine Fisheries -
North Shore Office
Attn: Environmental Reviewer
30 Emerson Avenue
Gloucester, MA 01930
Email: dmf.envreview-north@mass.gov

Also if yes, the project may require a Chapter 91 license. For coastal towns in the Northeast Region, please contact MassDEP's Boston Office. For coastal towns in the Southeast Region, please contact MassDEP's Southeast Regional Office.

- c. Is this an aquaculture project?

- d. Yes No

If yes, include a copy of the Division of Marine Fisheries Certification Letter (M.G.L. c. 130, § 57).

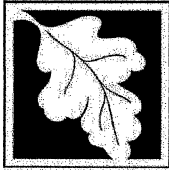

Massachusetts Department of Environmental Protection
Bureau of Resource Protection - Wetlands

WPA Form 3 – Notice of Intent

Massachusetts Wetlands Protection Act M.G.L. c. 131, §40

Provided by MassDEP:

MassDEP File Number

Document Transaction Number

Ashland

City/Town

C. Other Applicable Standards and Requirements (cont'd)

Online Users:
Include your document transaction number (provided on your receipt page) with all supplementary information you submit to the Department.

4. Is any portion of the proposed project within an Area of Critical Environmental Concern (ACEC)?
- a. Yes No If yes, provide name of ACEC (see instructions to WPA Form 3 or MassDEP Website for ACEC locations). **Note:** electronic filers click on Website.
- b. ACEC
5. Is any portion of the proposed project within an area designated as an Outstanding Resource Water (ORW) as designated in the Massachusetts Surface Water Quality Standards, 314 CMR 4.00?
- a. Yes No
6. Is any portion of the site subject to a Wetlands Restriction Order under the Inland Wetlands Restriction Act (M.G.L. c. 131, § 40A) or the Coastal Wetlands Restriction Act (M.G.L. c. 130, § 105)?
- a. Yes No
7. Is this project subject to provisions of the MassDEP Stormwater Management Standards?
- a. Yes. Attach a copy of the Stormwater Report as required by the Stormwater Management Standards per 310 CMR 10.05(6)(k)-(q) and check if:
1. Applying for Low Impact Development (LID) site design credits (as described in Stormwater Management Handbook Vol. 2, Chapter 3)
 2. A portion of the site constitutes redevelopment
 3. Proprietary BMPs are included in the Stormwater Management System.
- b. No. Check why the project is exempt:
1. Single-family house
 2. Emergency road repair
 3. Small Residential Subdivision (less than or equal to 4 single-family houses or less than or equal to 4 units in multi-family housing project) with no discharge to Critical Areas.

D. Additional Information

- This is a proposal for an Ecological Restoration Limited Project. Skip Section D and complete Appendix A: Ecological Restoration Notice of Intent – Minimum Required Documents (310 CMR 10.12).

Applicants must include the following with this Notice of Intent (NOI). See instructions for details.

Online Users: Attach the document transaction number (provided on your receipt page) for any of the following information you submit to the Department.

1. USGS or other map of the area (along with a narrative description, if necessary) containing sufficient information for the Conservation Commission and the Department to locate the site. (Electronic filers may omit this item.)
2. Plans identifying the location of proposed activities (including activities proposed to serve as a Bordering Vegetated Wetland [BVW] replication area or other mitigating measure) relative to the boundaries of each affected resource area.



Massachusetts Department of Environmental Protection
 Bureau of Resource Protection - Wetlands
WPA Form 3 – Notice of Intent
 Massachusetts Wetlands Protection Act M.G.L. c. 131, §40

Provided by MassDEP:
MassDEP File Number
Document Transaction Number
Ashland
City/Town

D. Additional Information (cont'd)

- 3. Identify the method for BVW and other resource area boundary delineations (MassDEP BVW Field Data Form(s), Determination of Applicability, Order of Resource Area Delineation, etc.), and attach documentation of the methodology.
- 4. List the titles and dates for all plans and other materials submitted with this NOI.

Plan showing Proposed Garage

a. Plan Title

Jarvis Land Survey, Inc.

Kevin J. Jarvis

b. Prepared By

c. Signed and Stamped by

8/19/2025

1"=40'

d. Final Revision Date

e. Scale

See attached D.4. Additional Information

f. Additional Plan or Document Title

g. Date

- 5. If there is more than one property owner, please attach a list of these property owners not listed on this form.
- 6. Attach proof of mailing for Natural Heritage and Endangered Species Program, if needed.
- 7. Attach proof of mailing for Massachusetts Division of Marine Fisheries, if needed.
- 8. Attach NOI Wetland Fee Transmittal Form
- 9. Attach Stormwater Report, if needed.

E. Fees

- 1. Fee Exempt: No filing fee shall be assessed for projects of any city, town, county, or district of the Commonwealth, federally recognized Indian tribe housing authority, municipal housing authority, or the Massachusetts Bay Transportation Authority.

Applicants must submit the following information (in addition to pages 1 and 2 of the NOI Wetland Fee Transmittal Form) to confirm fee payment:

11554 (1532 bylaw)

8/28/2025 (9/5/2025 bylaw)

2. Municipal Check Number

3. Check date

11553

8/28/2025

4. State Check Number

5. Check date

Salisbury Construction & EBT Environmental Consultants Inc.

7. Payor name on check: Last Name

D.4. Additional Information

Project Location: 27 Laurelton Drive, Ashland

Applicant: Paul & Barbara Todaro

- 1A. Plan showing Proposed Garage: prepared for Paul & Barbara Todaro by Jarvis Land Survey Inc., dated 8/19/2025
- 2A. Holliston USGS Quad, dated 2024
- 3A. Assessor's Map 23, dated 9/6/2017
- 4A. Fee Transmittal Form, Local Fee Sheet & Check Copies
- 5A. Town of Ashland Abutters' List, dated 9/15/2025
- 6A. Abutters Notification
- 7A. Affidavit of Service, dated 9/23/2025
- 8A. Straw Wattle & Silt Fence Detail



Massachusetts Department of Environmental Protection
Bureau of Resource Protection - Wetlands

WPA Form 3 – Notice of Intent

Massachusetts Wetlands Protection Act M.G.L. c. 131, §40

Provided by MassDEP:

MassDEP File Number

Document Transaction Number

City/Town

F. Signatures and Submittal Requirements

I hereby certify under the penalties of perjury that the foregoing Notice of Intent and accompanying plans, documents, and supporting data are true and complete to the best of my knowledge. I understand that the Conservation Commission will place notification of this Notice in a local newspaper at the expense of the applicant in accordance with the wetlands regulations, 310 CMR 10.05(5)(a).

I further certify under penalties of perjury that all abutters were notified of this application, pursuant to the requirements of M.G.L. c. 131, § 40. Notice must be made by Certificate of Mailing or in writing by hand delivery or certified mail (return receipt requested) to all abutters within 100 feet of the property line of the project location.

Barbara Todaro

1. Signature of Applicant

8/28/25

2. Date

Barbara Todaro

3. Signature of Property Owner (if different)

8/28/25

4. Date

Alean E. Krewosky

5. Signature of Representative (if any)

9/23/2025

6. Date

For Conservation Commission:

Two copies of the completed Notice of Intent (Form 3), including supporting plans and documents, two copies of the NOI Wetland Fee Transmittal Form, and the city/town fee payment, to the Conservation Commission by certified mail or hand delivery.

For MassDEP:

One copy of the completed Notice of Intent (Form 3), including supporting plans and documents, one copy of the NOI Wetland Fee Transmittal Form, and a **copy** of the state fee payment to the MassDEP Regional Office (see Instructions) by certified mail or hand delivery.

Other:

If the applicant has checked the "yes" box in any part of Section C, Item 3, above, refer to that section and the Instructions for additional submittal requirements.

The original and copies must be sent simultaneously. Failure by the applicant to send copies in a timely manner may result in dismissal of the Notice of Intent.

**PLAN SHOWING PROPOSED GARAGE
PREPARED FOR
BARBARA TODARO
27 LAURELTON DRIVE
ASHLAND, MASSACHUSETTS**

**JARVIS LAND SURVEY, INC
29 GRAFTON CIRCLE
SHREWSBURY, MA 01545
TEL. (508) 842-8087
FAX. (508) 842-0661
KEVIN@JARVISLANDSURVEY.COM**

**AUGUST 19, 2025
SCALE: 1 INCH = 40 FEET**

*** THE SURVEYOR RETAINS COPYRIGHT TO THE PLAN OF SURVEY, AND RE-USE OF THIS PLAN IS NOT ALLOWED WITHOUT PERMISSION FROM THE SURVEYOR.**

1. THIS PLAN HAS BEEN PREPARED WITHOUT THE BENEFIT OF A TITLE REPORT AND IS SUBJECT TO THE FINDINGS SUCH A REPORT MIGHT DISCLOSE.

2. THIS PLAN HAS NOT BEEN PREPARED FOR RECORDING PURPOSES.

3. THE LICENSED MATERIAL CONTAINS VALUABLE PROPRIETARY INFORMATION BELONGING EXCLUSIVELY TO JARVIS LAND SURVEY, INC. THE LICENSED MATERIAL AND THE INFORMATION CONTAINED THEREON ARE COPYRIGHTED INSTRUMENTS OF PROFESSIONAL SERVICES AND SHALL NOT BE USED, IN WHOLE OR IN PART, FOR ANY PROJECT OTHER THAN THAT FOR WHICH THEY WERE CREATED, WITHOUT THE EXPRESS WRITTEN CONSENT OF JARVIS LAND SURVEY, INC. YOU AGREE NEVER TO REMOVE ANY NOTICES OF COPYRIGHT, NOR TO REPRODUCE OR MODIFY THE LICENSED MATERIAL.

**ASSESSORS MAP 140-23
LOT 182**

8-19-2025

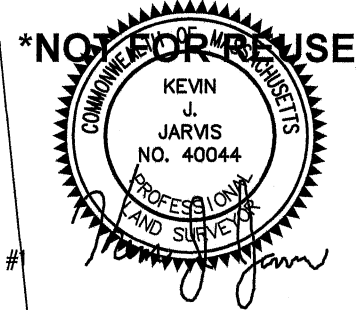

ZONING DATA:

RES. A
LOT AREA = 30,000 S.F.
LOT FRONTAGE = 150'
FRONT YARD SETBACK = 40'
SIDE YARD SETBACK = 10'
REAR YARD SETBACK = 30'

MITIGATION PLANTING AREA #1
(3) COMMON WINTERBERRY
(3) Highbush BLUEBERRY
(2) NORTHERN ARROWWOOD
NE WILDFLOWER MIX

PILE OF ROCKS (HOLDING UP DIRT)

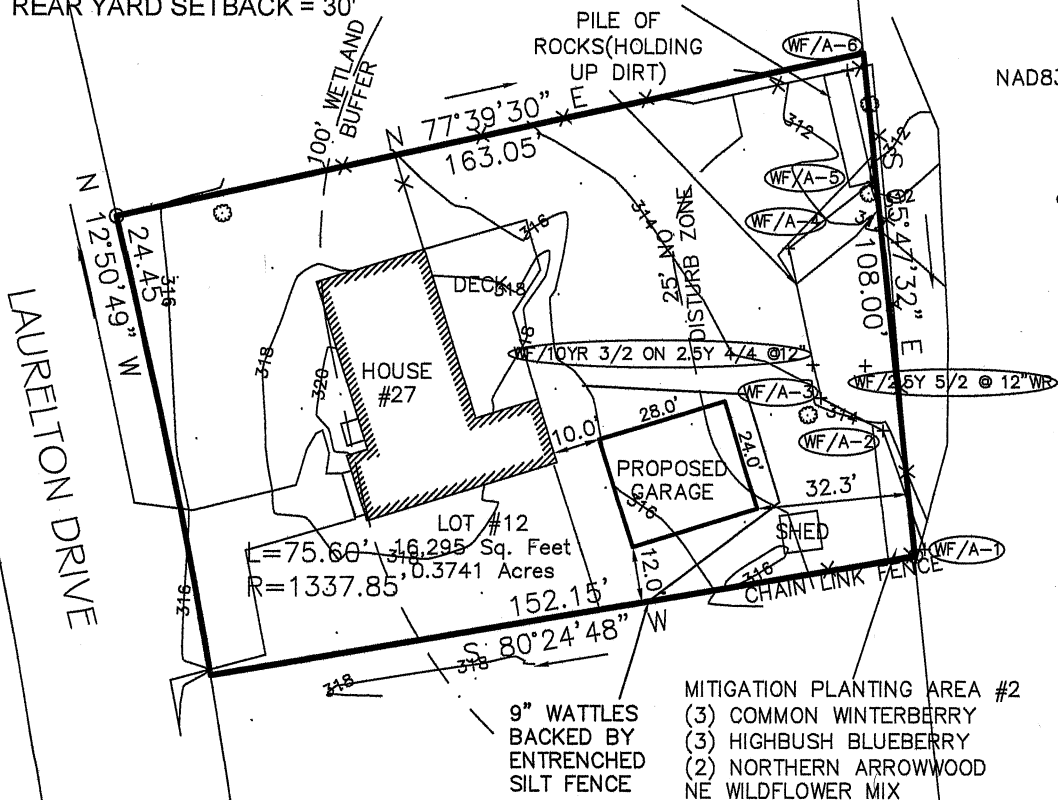

9" WATTLES
BACKED BY
ENTRENCHED
SILT FENCE

MITIGATION PLANTING AREA #2
(3) COMMON WINTERBERRY
(3) Highbush BLUEBERRY
(2) NORTHERN ARROWWOOD
NE WILDFLOWER MIX



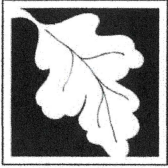

Massachusetts Department of Environmental Protection
 Bureau of Resource Protection - Wetlands
NOI Wetland Fee Transmittal Form
 Massachusetts Wetlands Protection Act M.G.L. c. 131, §40

Important: When filling out forms on the computer, use only the tab key to move your cursor - do not use the return key.

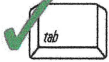

A. Applicant Information

1. Location of Project:

<u>27 Laurelton Drive</u>	<u>Ashland</u>
a. Street Address	b. City/Town
<u>11553 (11554 municipal & 1532 bylaw)</u>	<u>\$42.50 (\$67.50 municipal & \$310.00 bylaw)</u>
c. Check number	d. Fee amount

2. Applicant Mailing Address:

<u>Paul & Barbara</u>	<u>Todaro</u>	
a. First Name	b. Last Name	
c. Organization		
<u>27 Laurelton Drive</u>		
d. Mailing Address		
<u>Ashland</u>	<u>MA</u>	<u>01721</u>
e. City/Town	f. State	g. Zip Code
<u>(508) 397-4518</u>	<u>bltodaro10@gmail.com</u>	
h. Phone Number	i. Fax Number	j. Email Address

3. Property Owner (if different):

<u>(Same as above)</u>		
a. First Name	b. Last Name	
c. Organization		
d. Mailing Address		
<u></u>	<u></u>	<u></u>
e. City/Town	f. State	g. Zip Code
<u></u>	<u></u>	<u></u>
h. Phone Number	i. Fax Number	j. Email Address

To calculate filing fees, refer to the category fee list and examples in the instructions for filling out WPA Form 3 (Notice of Intent).

B. Fees

Fee should be calculated using the following process & worksheet. **Please see Instructions before filling out worksheet.**

Step 1/Type of Activity: Describe each type of activity that will occur in wetland resource area and buffer zone.

Step 2/Number of Activities: Identify the number of each type of activity.

Step 3/Individual Activity Fee: Identify each activity fee from the six project categories listed in the instructions.

Step 4/Subtotal Activity Fee: Multiply the number of activities (identified in Step 2) times the fee per category (identified in Step 3) to reach a subtotal fee amount. Note: If any of these activities are in a Riverfront Area in addition to another Resource Area or the Buffer Zone, the fee per activity should be multiplied by 1.5 and then added to the subtotal amount.

Step 5/Total Project Fee: Determine the total project fee by adding the subtotal amounts from Step 4.

Step 6/Fee Payments: To calculate the state share of the fee, divide the total fee in half and subtract \$12.50. To calculate the city/town share of the fee, divide the total fee in half and add \$12.50.

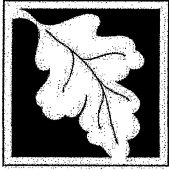

Massachusetts Department of Environmental Protection
 Bureau of Resource Protection - Wetlands
NOI Wetland Fee Transmittal Form
 Massachusetts Wetlands Protection Act M.G.L. c. 131, §40

B. Fees (continued)

Step 1/Type of Activity	Step 2/Number of Activities	Step 3/Individual Activity Fee	Step 4/Subtotal Activity Fee
Category 1.a.	1	\$110.00	\$110.00

Step 5/Total Project Fee: \$110.00 (+\$310.00 bylaw)

Step 6/Fee Payments:

Total Project Fee:	\$110.00 (+\$310 bylaw)
State share of filing Fee:	\$42.50
City/Town share of filling Fee:	\$67.50 (+\$310 bylaw)
	a. Total Fee from Step 5
	b. 1/2 Total Fee less \$12.50
	c. 1/2 Total Fee plus \$12.50

C. Submittal Requirements

- a.) Complete pages 1 and 2 and send with a check or money order for the state share of the fee, payable to the Commonwealth of Massachusetts.

Department of Environmental Protection
 Box 4062
 Boston, MA 02211

- b.) **To the Conservation Commission:** Send the Notice of Intent or Abbreviated Notice of Intent; a **copy** of this form; and the city/town fee payment.

To MassDEP Regional Office (see Instructions): Send a copy of the Notice of Intent or Abbreviated Notice of Intent; a **copy** of this form; and a **copy** of the state fee payment. (E-filers of Notices of Intent may submit these electronically.)

SALISBURY CONSTRUCTION
453 Chandler Street, Worcester, MA 01602

M & T BANK
4 MOWER ST
WORCESTER, MA 01612

11553

10-4/220
8433

8/28/2025

PAY TO THE ORDER OF **Commonwealth of Massachusetts**

\$ **42.50

Forty-Two and 50/100*****

DOLLARS

Commonwealth of Massachusetts

MEMO

Jonathan Lopez
AUTHORIZED SIGNATURE

MP

SALISBURY CONSTRUCTION
453 Chandler Street, Worcester, MA 01602

M & T BANK
4 MOWER ST
WORCESTER, MA 01612

11554

10-4/220
8433

8/28/2025

PAY TO THE ORDER OF **Town of Ashland**

\$ **67.50

Sixty-Seven and 50/100*****

DOLLARS

Town of Ashland

MEMO

Jonathan Lopez
AUTHORIZED SIGNATURE

MP

Z EBT ENVIRONMENTAL CONSULTANTS INC
601 MAIN ST
NORTH OXFORD, MA 01537-1305

1532

53-13/110 MA
1876

DATE 9/5/2025

PAY TO THE ORDER OF Town of Ashland

\$ 310 ⁰⁰/₁₀₀

Three Hundred and Ten ⁰⁰/₁₀₀

DOLLARS

BANK OF AMERICA

ACH R/T 011000138

FOR 27 Laurellen Bylaw NOE Fee

Glenne Krawsky

Photo Safe Deposit Cash on Back

MP

September 11, 2025

To The Conservation Commission
27 Laurelton Drive
Paul and Barbara Todaro
Abutters To Map 23 Parcel 182

PARCEL ID	PARCEL ADDRESS	OWNER NAME 1	OWNER NAME 2	MAILING ADDRESS	CITY/TOWN	STATE	ZIP
014/023.0-0181-0000.0	0 OLIVE ST REAR	CAPPADONNA ROSE M	TRUSTEE OF 101 OLIVE ST TRUST	101 OLIVE ST	ASHLAND	MA	01721
014/023.0-0183-0000.0	31 LAURELTON DR	COSTA ADILSON DESOUZA		31 LAURELTON DR	ASHLAND	MA	01721
014/023.0-0187-0000.0	34 LAURELTON DR	SPRAGUE DEBORAH A		34 LAURELTON DR	ASHLAND	MA	01721
014/023.0-0188-0000.0	30 LAURELTON DR	PELLETIER LINDA E	ROSS A PELLETIER	30 LAURELTON DR	ASHLAND	MA	01721
014/027.0-0012-0000.0	22 LAURELTON DR	ANTONELLIS JOSEPH L	LINDA J ANTONELLIS	22 LAURELTON DR	ASHLAND	MA	01721
014/027.0-0013-0000.0	26 LAURELTON DR	GENTILUCCI ELISE M	IVANO GENTILUCCI	26 LAURELTON DR	ASHLAND	MA	01721
014/027.0-0014-0000.0	23 LAURELTON DR	HEATON ROBERT C & ALICE M	TRSTS ALICE M HEATON TRUST	23 LAURELTON DR	ASHLAND	MA	01721
014/027.0-0015-0000.0	19 LAURELTON DR	STIFFLER GAIL A		19 LAURELTON DR	ASHLAND	MA	01721

The above reflects the latest information available on our records.

Terry Capen
Senior Clerk

Date

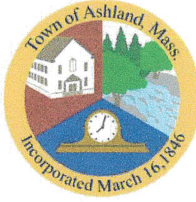

Town of Ashland, Office of Conservation

NOTIFICATION TO ABUTTERS

A/An Notice of Intent

has been filed with the **Ashland Conservation Commission** pursuant to the *Wetlands Protection Act (M.G.L. c. 131 §40)*, *Wetlands Protection Act Regulations 310 C.M.R. 10.05 (4)(a)* and the *Wetlands Protection Bylaw Chapter 280 Section 9*, and/or the *Stormwater Management Regulations Chapter 343*.

The applicant is Paul & Barbara Todaro

The proposed project is located at 27 Laurelton Drive, Ashland
in Ashland, Massachusetts. The proposed project is:

The applicant proposes to construct a 24' by 28' garage within the 100-foot buffer zone and partially within the 25' bylaw no disturb zone to a bordering vegetated wetland.

The filing may be examined by electronic means only. For more information, or to request a pdf filing submittal, please call 508-532-7924, and ask for the Conservation Agent.

The public hearing is scheduled for **Monday, October 20, 2025, at 7:05 p.m.** (*Note that all hearings are posted for 7:05 unless otherwise specified on the agenda. Hearings are taken in order of the posted agenda*). The hearing will be held using a **REMOTE format**, online via Zoom. The link for the meeting can be found on the posted agenda 48 hours before the hearing is scheduled to meet. Otherwise, further information of the public hearing can be obtained from the Ashland Conservation Commission, by calling 508-532-7924.

AFFIDAVIT OF SERVICE

**UNDER THE MASSACHUSETTS WETLANDS PROTECTION ACT
AND TOWN OF ASHLAND WETLAND PROTECTION BYLAW**

(To be submitted to the Massachusetts Department of Environmental Protection & the Conservation Commission when filing a Notice of Intent)

I, Glenn E. Krevosky, hereby certify under the pains and penalties of perjury that on September 23, 2025, I gave notification to abutters within 100 feet of the proposed project in compliance with the second paragraph of the Massachusetts General Laws, Chapter 131, Section 40 and the DEP Guide to Abutter Notification, dated April 8, 1994, in connection with the following matter:

A Notice of Intent (NOI) application filed under the Massachusetts Wetlands Protection Act and The Town of Ashland Wetland Protection Bylaw by EBT Environmental Consultants, Inc., 601 Main Street, North Oxford, MA 01537, with the Ashland Conservation Commission on September 23, 2025 for a property located at, 27 Laurelton Drive, Ashland.

The form of the notification and the list of the abutters to whom it was given and their addresses are attached to this Affidavit of Service.

Glenn E. Krevosky
Signature

9-23-2025
Date

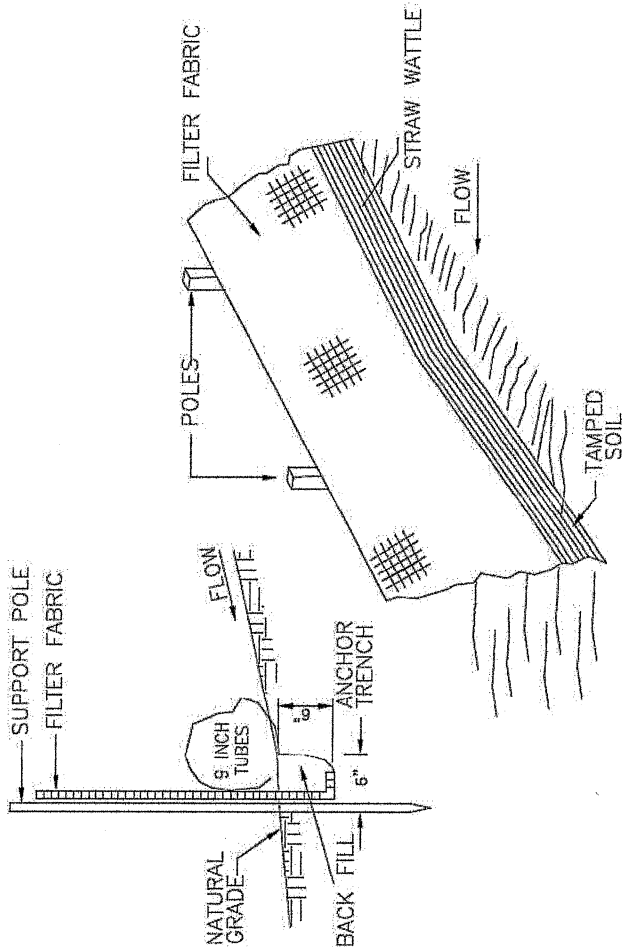

FOR SILT FENCE USE ENVIROFENCE
OR APPROVED EQUAL. INSTALL BY
RECOMMENDED TOE-IN TRENCH METHOD.

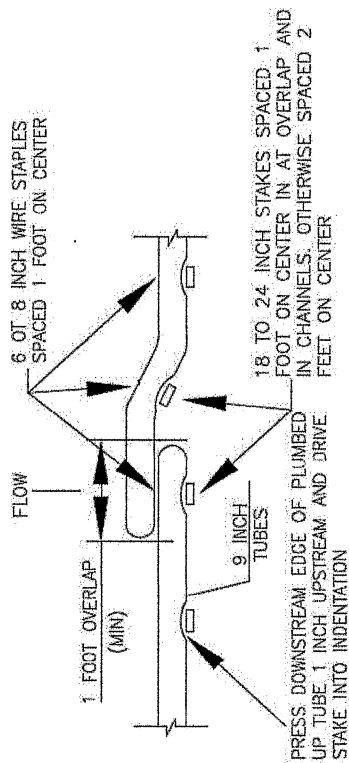

OVERLAP/JOINT DETAIL

- GENERAL NOTES:
- 1) TUBES WITH FLOCCULANT MAY BE INSTALLED BEFORE OR AFTER THE INSTALLATION OF ROLLED EROSION CONTROL PRODUCTS. BEFORE INSTALLATION OF TUBE, SMOOTH AND SHAPE EARTH SURFACE AND REMOVE ALL STONES, ROOTS, OR OTHER DEBRIS GREATER THAN 2 INCHES IN DIAMETER.
 - 2) IF INSTALLING TUBE ACROSS A DITCH, THEN EXCAVATE A PLACEMENT TRENCH ABOUT 3 INCHES DEEP.

STRAW WATTLE/SILT FENCE DETAIL
(N.T.S.)