

LETTER OF TRANSMITTAL

To: Ashland Conservation
Commission
101 Main Street
Ashland, MA 01721

Date: April 4, 2022
Re: Matt Lundsted
41 Main Street
Bolton, MA 01740

Attention: _____

Project: Sudbury River Access Facility

We are sending you Enclosed Under separate cover via Mail Messenger, the following items

- shop drawings prints data sheets Project Plans
 specifications sketches brochures Permit Application

COPIES	PREPARED BY	JOB OR CONTRACT NO.	DESCRIPTION
2	CEI	346-4	Notice of Intent Permit Application
2	CEI	346-4	Full-Scale Permit Plans (36 x 24)

THESE ARE TRANSMITTED AS CHECKED BELOW:

- As requested Approved Resubmit ___ copies for approval
 For your use Approved as Corrected Submit ___ copies for distribution
 For review & comment Revise and Resubmit Return _____ corrected prints
 For your information Not Approved _____

Remarks: _____

Copies to: MassDEP Northeast Regional
Office - Wilmington
205B Lowell Street
Wilmington, MA 01887

Sent by: Matt Lundsted, CEI
 Telephone: 1-800-725-2550 ext. 305



Notice of Intent (NOI)

for

**Ashland, Massachusetts
Aikens Road
Sudbury River Access Facility**

April 2022

Prepared For:
Town of Ashland
101 Main Street
Ashland, MA 01721

Office of Fishing and Boating Access
1 Rabbit Hill Road
Westborough, MA 01581

Prepared By:
Comprehensive Environmental Inc.
41 Main Street
Bolton, Massachusetts 01740



Notice of Intent

Part A: Transmittal Form – Notice of Intent

Part B: NOI Wetland Fee Transmittal Form

Part C: WPA Form 3

Part D: Notice of Intent Narrative:

1.0 Introduction

1.1 Project Location & Property Owners

2.0 Description of Proposed Work

2.1 Existing Conditions

2.1.1 Wetland Delineation

3.0 Proposed Resource Area Impacts and Mitigation

3.1 Bank (310 CMR 10.54)

3.2 Bordering Vegetated Wetlands and Buffer Zone (310 CMR 10.55)

3.3 Land Under Waterbodies (310 CMR 10.56)

3.4 Bordering Land Subject to Flooding (310 CMR 10.57)

3.5 100-foot Buffer Zone

3.6 Riverfront Area (310 CMR 10.58)

3.7 25-foot No-Disturb Zone (Ashland Wetland Protection Regulations)

3.8 Alternatives Analysis

1. Alternative 1: No action

2. Alternative 2: Wooden Fishing Pier Extending over the River with Parking

3. Alternative 3: Stone Access Paths and Fishing Area with Parking

4.0 Construction Sequence

5.0 Protective Measures

6.0 Stormwater Standards Report

7.0 Permission Letters and Abutter Notification



Appendices

Appendix A – USGS Locus Map

Appendix B – Site Photographs

Appendix C – FEMA Flood Insurance Rate Map (FIRM)

Appendix D – Natural Heritage & Endangered Species Program (NHESP) Map

Appendix E – Soils Map

Appendix F – Town of Ashland Parcel Maps and Abutter List

Appendix G – Abutter Notification Letter and Certified Mail Receipts

Appendix H – Stormwater Report Checklist

Appendix I – Flood Storage Calculations (Cut/Fill Analysis)

Appendix J – Permit Plans





Enter your transmittal number



Transmittal Number

Your unique Transmittal Number can be accessed online:

<http://www.mass.gov/eea/agencies/massdep/service/approvals/transmittal-form-for-payment.html>

Massachusetts Department of Environmental Protection

Transmittal Form for Permit Application and Payment

1. Please type or print. A separate Transmittal Form must be completed for each permit application.

A. Permit Information

WPA Form 3

Notice of Intent

1. Permit Code: 4 to 7 character code from permit instructions

2. Name of Permit Category

Sudbury River Access Facility Project - Ashland, MA

3. Type of Project or Activity

2. Make your check payable to the Commonwealth of Massachusetts and mail it with a copy of this form to: MassDEP, P.O. Box 4062, Boston, MA 02211.

B. Applicant Information – Firm or Individual

Office of Fishing and Boating Access

1. Name of Firm - Or, if party needing this approval is an individual enter name below:

Cameron

Douglas

H.

2. Last Name of Individual

3. First Name of Individual

4. MI

1 Rabbit Hill Road

5. Street Address

Westborough

MA

01581

617-828-3532

6. City/Town

7. State

8. Zip Code

9. Telephone #

10. Ext. #

11. Contact Person

doug.cameron@mass.gov

12. e-mail address

3. Three copies of this form will be needed.

Copy 1 - the original must accompany your permit application. Copy 2 must accompany your fee payment. Copy 3 should be retained for your records

C. Facility, Site or Individual Requiring Approval

Sudbury River Access Facility

1. Name of Facility, Site Or Individual

0 Aikens Road

2. Street Address

Ashland

MA

01721

3. City/Town

4. State

5. Zip Code

6. Telephone #

7. Ext. #

N/A

N/A

N/A

8. DEP Facility Number (if Known)

9. Federal I.D. Number (if Known)

10. BWSC Tracking # (if Known)

4. Both fee-paying and exempt applicants must mail a copy of this transmittal form to:

MassDEP
P.O. Box 4062
Boston, MA
02211

D. Application Prepared by (if different from Section B)*

Comprehensive Environmental Inc.

1. Name of Firm Or Individual

41 Main Street

2. Address

Bolton

MA

01740

800-725-2550

305

3. City/Town

4. State

5. Zip Code

6. Telephone #

7. Ext. #

Matthew Lundsted

N/A

8. Contact Person

9. LSP Number (BWSC Permits only)

* Note: For BWSC Permits, enter the LSP.

E. Permit - Project Coordination

1. Is this project subject to MEPA review? yes no
If yes, enter the project's EOE file number - assigned when an Environmental Notification Form is submitted to the MEPA unit:

N/A

EOEA File Number

F. Amount Due

DEP Use Only

Special Provisions:

- 1. Fee Exempt (city, town or municipal housing authority)(state agency if fee is \$100 or less). There are no fee exemptions for BWSC permits, regardless of applicant status.
2. Hardship Request - payment extensions according to 310 CMR 4.04(3)(c).
3. Alternative Schedule Project (according to 310 CMR 4.05 and 4.10).
4. Homeowner (according to 310 CMR 4.02).

Permit No:

Rec'd Date:

Reviewer:

Check Number

Dollar Amount

Date



Massachusetts Department of Environmental Protection
Bureau of Resource Protection - Wetlands
NOI Wetland Fee Transmittal Form
Massachusetts Wetlands Protection Act M.G.L. c. 131, §40

Important: When filling out forms on the computer, use only the tab key to move your cursor - do not use the return key.

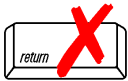

A. Applicant Information

1. Location of Project:

Aikens Road (42.2662573, -71.5209618)

a. Street Address

Ashland

b. City/Town

26804

c. Check number

\$362.50

d. Fee amount

2. Applicant Mailing Address:

Douglas

a. First Name

Cameron

b. Last Name

Office of Fishing and Boating Access

c. Organization

1 Rabbit Hill Road

d. Mailing Address

Westborough

e. City/Town

MA

f. State

01581

g. Zip Code

617-828-3532

h. Phone Number

508-389-7890

i. Fax Number

doug.cameron@mass.gov

j. Email Address

3. Property Owner (if different):

Commonwealth of Massachusetts

c. Organization

100 Cambridge Street

d. Mailing Address

Boston

e. City/Town

MA

f. State

02110

g. Zip Code

h. Phone Number

i. Fax Number

j. Email Address

To calculate filing fees, refer to the category fee list and examples in the instructions for filling out WPA Form 3 (Notice of Intent).

B. Fees

Fee should be calculated using the following process & worksheet. **Please see Instructions before filling out worksheet.**

Step 1/Type of Activity: Describe each type of activity that will occur in wetland resource area and buffer zone.

Step 2/Number of Activities: Identify the number of each type of activity.

Step 3/Individual Activity Fee: Identify each activity fee from the six project categories listed in the instructions.

Step 4/Subtotal Activity Fee: Multiply the number of activities (identified in Step 2) times the fee per category (identified in Step 3) to reach a subtotal fee amount. Note: If any of these activities are in a Riverfront Area in addition to another Resource Area or the Buffer Zone, the fee per activity should be multiplied by 1.5 and then added to the subtotal amount.

Step 5/Total Project Fee: Determine the total project fee by adding the subtotal amounts from Step 4.

Step 6/Fee Payments: To calculate the state share of the fee, divide the total fee in half and subtract \$12.50. To calculate the city/town share of the fee, divide the total fee in half and add \$12.50.

Municipal Fee Calculation for Ashland, Ma Sudbury River Access Facility

Category 5 → docks, piers, engineering near other inland resource areas

61 Linear Feet of proposed impacts → **\$244** in municipal filing fees

Permit Type	Fee Amount
Request for Determination of Applicability	\$125.00
Notice of Intent or Abbreviated Notice of Resource Area Delineation Category 1	\$110.00
Notice of Intent or Abbreviated Notice of Resource Area Delineation Category 2	\$500.00
Notice of Intent or Abbreviated Notice of Resource Area Delineation Category 3	\$1,050.00
Notice of Intent or Abbreviated Notice of Resource Area Delineation Category 4	\$1,450.00
Notice of Intent or Abbreviated Notice of Resource Area Delineation Category 5	\$4 per linear foot (not less than \$100.00 not more than \$2,000.00)
Notice of Intent or Abbreviated Notice of Resource Area Delineation Category 6	\$2.00 per linear foot (\$200.00 maximum for a single family home, and \$2,000 for all others.
Request for Permit Extension	\$100.00
Request for Certificate of Compliance	Single Family Lot \$100.00 All other lots \$250.00
Reissuance of any Order, Determination, or Certificate	\$50.00



Massachusetts Department of Environmental Protection
Bureau of Resource Protection - Wetlands

WPA Form 3 – Notice of Intent

Massachusetts Wetlands Protection Act M.G.L. c. 131, §40

Provided by MassDEP:

MassDEP File Number

Document Transaction Number

Ashland, MA

City/Town

Important:

When filling out forms on the computer, use only the tab key to move your cursor - do not use the return key.



Note:
Before completing this form consult your local Conservation Commission regarding any municipal bylaw or ordinance.

A. General Information

1. Project Location (**Note:** electronic filers will click on button to locate project site):

<u>0 Aikens Road</u>	<u>Ashland</u>	<u>01721</u>
a. Street Address	b. City/Town	c. Zip Code
Latitude and Longitude:	<u>42.2662573</u>	<u>-71.5209618</u>
	d. Latitude	e. Longitude
<u>14</u>	<u>006.0-001-0000.0</u>	
f. Assessors Map/Plat Number	g. Parcel /Lot Number	

2. Applicant:

<u>Douglas</u>	<u>Cameron</u>	
a. First Name	b. Last Name	
<u>Office of Fishing and Boating Access</u>		
c. Organization		
<u>1 Rabbit Hill Road</u>		
d. Street Address		
<u>Westborough</u>	<u>MA</u>	<u>01581</u>
e. City/Town	f. State	g. Zip Code
<u>617-828-3532</u>	<u>508-389-7890</u>	<u>doug.cameron@mass.gov</u>
h. Phone Number	i. Fax Number	j. Email Address

3. Property owner (required if different from applicant): Check if more than one owner

<u></u>	<u></u>	
a. First Name	b. Last Name	
<u>Commonwealth of Massachusetts</u>		
c. Organization		
<u>100 Cambridge Street</u>		
d. Street Address		
<u>Boston</u>	<u>MA</u>	<u>02110</u>
e. City/Town	f. State	g. Zip Code
<u></u>	<u></u>	<u></u>
h. Phone Number	i. Fax Number	j. Email address

4. Representative (if any):

<u>Matthew</u>	<u>Lundsted</u>	
a. First Name	b. Last Name	
<u>Comprehensive Environmental, Inc.</u>		
c. Company		
<u>41 Main Street</u>		
d. Street Address		
<u>Bolton</u>	<u>MA</u>	<u>01740</u>
e. City/Town	f. State	g. Zip Code
<u>508-281-5160 x305</u>	<u>508-281-5136</u>	<u>mlundsted@ceiengineers.com</u>
h. Phone Number	i. Fax Number	j. Email address

5. Total WPA Fee Paid (from NOI Wetland Fee Transmittal Form):

<u>\$750</u>	<u>\$362.50</u>	<u>\$387.50</u>
a. Total Fee Paid	b. State Fee Paid	c. City/Town Fee Paid

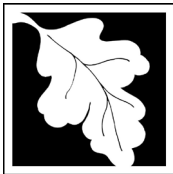

Massachusetts Department of Environmental Protection
Bureau of Resource Protection - Wetlands

WPA Form 3 – Notice of Intent

Massachusetts Wetlands Protection Act M.G.L. c. 131, §40

Provided by MassDEP:
MassDEP File Number
Document Transaction Number
Ashland, MA
City/Town

A. General Information (continued)

6. General Project Description:

This project proposes to create a fishing pier, kayak/canoe launch, and designated parking area along Aikens Road and the Sudbury River in Ashland, MA.

7a. Project Type Checklist: (Limited Project Types see Section A. 7b.)

- 1. Single Family Home
- 2. Residential Subdivision
- 3. Commercial/Industrial
- 4. Dock/Pier
- 5. Utilities
- 6. Coastal engineering Structure
- 7. Agriculture (e.g., cranberries, forestry)
- 8. Transportation
- 9. Other

7b. Is any portion of the proposed activity eligible to be treated as a limited project (including Ecological Restoration Limited Project) subject to 310 CMR 10.24 (coastal) or 310 CMR 10.53 (inland)?

- 1. Yes No If yes, describe which limited project applies to this project. (See 310 CMR 10.24 and 10.53 for a complete list and description of limited project types)

2. Limited Project Type

If the proposed activity is eligible to be treated as an Ecological Restoration Limited Project (310 CMR10.24(8), 310 CMR 10.53(4)), complete and attach Appendix A: Ecological Restoration Limited Project Checklist and Signed Certification.

8. Property recorded at the Registry of Deeds for:

a. County	b. Certificate # (if registered land)
c. Book	d. Page Number

B. Buffer Zone & Resource Area Impacts (temporary & permanent)

- 1. Buffer Zone Only – Check if the project is located only in the Buffer Zone of a Bordering Vegetated Wetland, Inland Bank, or Coastal Resource Area.
- 2. Inland Resource Areas (see 310 CMR 10.54-10.58; if not applicable, go to Section B.3, Coastal Resource Areas).

Check all that apply below. Attach narrative and any supporting documentation describing how the project will meet all performance standards for each of the resource areas altered, including standards requiring consideration of alternative project design or location.

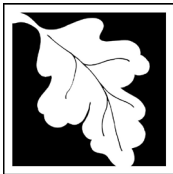

Massachusetts Department of Environmental Protection
Bureau of Resource Protection - Wetlands

WPA Form 3 – Notice of Intent

Massachusetts Wetlands Protection Act M.G.L. c. 131, §40

Provided by MassDEP:

MassDEP File Number

Document Transaction Number

Ashland, MA

City/Town

B. Buffer Zone & Resource Area Impacts (temporary & permanent) (cont'd)

For all projects affecting other Resource Areas, please attach a narrative explaining how the resource area was delineated.

Resource Area	Size of Proposed Alteration	Proposed Replacement (if any)
a. <input checked="" type="checkbox"/> Bank	61 1. linear feet	2. linear feet
b. <input checked="" type="checkbox"/> Bordering Vegetated Wetland	653 1. square feet	2. square feet
c. <input type="checkbox"/> Land Under Waterbodies and Waterways	_____ 1. square feet _____ 3. cubic yards dredged	2. square feet

Resource Area	Size of Proposed Alteration	Proposed Replacement (if any)
d. <input checked="" type="checkbox"/> Bordering Land Subject to Flooding	2,100 1. square feet	2. square feet
e. <input type="checkbox"/> Isolated Land Subject to Flooding	213 3. cubic feet of flood storage lost	354 4. cubic feet replaced
	_____ 1. square feet _____ 2. cubic feet of flood storage lost	3. cubic feet replaced
f. <input checked="" type="checkbox"/> Riverfront Area	Sudbury River - inland 1. Name of Waterway (if available) - specify coastal or inland	

2. Width of Riverfront Area (check one):

- 25 ft. - Designated Densely Developed Areas only
- 100 ft. - New agricultural projects only
- 200 ft. - All other projects

3. Total area of Riverfront Area on the site of the proposed project: _____ square feet

4. Proposed alteration of the Riverfront Area:

9,399	9,399	0 SF
a. total square feet	b. square feet within 100 ft.	c. square feet between 100 ft. and 200 ft.

5. Has an alternatives analysis been done and is it attached to this NOI? Yes No

6. Was the lot where the activity is proposed created prior to August 1, 1996? Yes No

3. Coastal Resource Areas: (See 310 CMR 10.25-10.35)

Note: for coastal riverfront areas, please complete **Section B.2.f.** above.

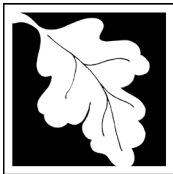

Massachusetts Department of Environmental Protection
 Bureau of Resource Protection - Wetlands

WPA Form 3 – Notice of Intent

Massachusetts Wetlands Protection Act M.G.L. c. 131, §40

Provided by MassDEP:

MassDEP File Number

Document Transaction Number

Ashland, MA

City/Town

B. Buffer Zone & Resource Area Impacts (temporary & permanent) (cont'd)

Check all that apply below. Attach narrative and supporting documentation describing how the project will meet all performance standards for each of the resource areas altered, including standards requiring consideration of alternative project design or location.

Online Users:
 Include your document transaction number (provided on your receipt page) with all supplementary information you submit to the Department.

<u>Resource Area</u>	<u>Size of Proposed Alteration</u>	<u>Proposed Replacement (if any)</u>
a. <input type="checkbox"/> Designated Port Areas	Indicate size under Land Under the Ocean, below	
b. <input type="checkbox"/> Land Under the Ocean	_____	
	1. square feet	

	2. cubic yards dredged	
c. <input type="checkbox"/> Barrier Beach	Indicate size under Coastal Beaches and/or Coastal Dunes below	
d. <input type="checkbox"/> Coastal Beaches	_____	_____
	1. square feet	2. cubic yards beach nourishment
e. <input type="checkbox"/> Coastal Dunes	_____	_____
	1. square feet	2. cubic yards dune nourishment
	<u>Size of Proposed Alteration</u>	<u>Proposed Replacement (if any)</u>
f. <input type="checkbox"/> Coastal Banks	_____	
	1. linear feet	
g. <input type="checkbox"/> Rocky Intertidal Shores	_____	
	1. square feet	
h. <input type="checkbox"/> Salt Marshes	_____	_____
	1. square feet	2. sq ft restoration, rehab., creation
i. <input type="checkbox"/> Land Under Salt Ponds	_____	
	1. square feet	

	2. cubic yards dredged	
j. <input type="checkbox"/> Land Containing Shellfish	_____	
	1. square feet	
k. <input type="checkbox"/> Fish Runs	Indicate size under Coastal Banks, inland Bank, Land Under the Ocean, and/or inland Land Under Waterbodies and Waterways, above	

	1. cubic yards dredged	
l. <input type="checkbox"/> Land Subject to Coastal Storm Flowage	_____	
	1. square feet	
4. <input type="checkbox"/> Restoration/Enhancement	If the project is for the purpose of restoring or enhancing a wetland resource area in addition to the square footage that has been entered in Section B.2.b or B.3.h above, please enter the additional amount here.	
	_____	_____
	a. square feet of BVW	b. square feet of Salt Marsh
5. <input type="checkbox"/> Project Involves Stream Crossings		
	0	1
	_____	_____
	a. number of new stream crossings	b. number of replacement stream crossings

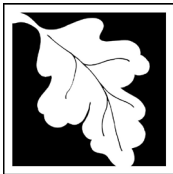

Massachusetts Department of Environmental Protection
Bureau of Resource Protection - Wetlands

WPA Form 3 – Notice of Intent

Massachusetts Wetlands Protection Act M.G.L. c. 131, §40

Provided by MassDEP:

MassDEP File Number

Document Transaction Number

Ashland, MA

City/Town

C. Other Applicable Standards and Requirements

- This is a proposal for an Ecological Restoration Limited Project. Skip Section C and complete Appendix A: Ecological Restoration Limited Project Checklists – Required Actions (310 CMR 10.11).

Streamlined Massachusetts Endangered Species Act/Wetlands Protection Act Review

- Is any portion of the proposed project located in **Estimated Habitat of Rare Wildlife** as indicated on the most recent Estimated Habitat Map of State-Listed Rare Wetland Wildlife published by the Natural Heritage and Endangered Species Program (NHESP)? To view habitat maps, see the *Massachusetts Natural Heritage Atlas* or go to http://maps.massgis.state.ma.us/PRI_EST_HAB/viewer.htm.

- a. Yes No **If yes, include proof of mailing or hand delivery of NOI to:**

**Natural Heritage and Endangered Species Program
Division of Fisheries and Wildlife
1 Rabbit Hill Road
Westborough, MA 01581**

- 2018 _____
b. Date of map

If yes, the project is also subject to Massachusetts Endangered Species Act (MESA) review (321 CMR 10.18). To qualify for a streamlined, 30-day, MESA/Wetlands Protection Act review, please complete Section C.1.c, and include requested materials with this Notice of Intent (NOI); *OR* complete Section C.2.f, if applicable. *If MESA supplemental information is not included with the NOI, by completing Section 1 of this form, the NHESP will require a separate MESA filing which may take up to 90 days to review (unless noted exceptions in Section 2 apply, see below).*

- c. Submit Supplemental Information for Endangered Species Review*

- Percentage/acreage of property to be altered:
 - (a) within wetland Resource Area _____ percentage/acreage
 - (b) outside Resource Area _____ percentage/acreage

- Assessor's Map or right-of-way plan of site

- Project plans for entire project site, including wetland resource areas and areas outside of wetlands jurisdiction, showing existing and proposed conditions, existing and proposed tree/vegetation clearing line, and clearly demarcated limits of work **
 - (a) Project description (including description of impacts outside of wetland resource area & buffer zone)
 - (b) Photographs representative of the site

* Some projects **not** in Estimated Habitat may be located in Priority Habitat, and require NHESP review (see <http://www.mass.gov/eea/agencies/dfg/dfw/natural-heritage/regulatory-review/>). Priority Habitat includes habitat for state-listed plants and strictly upland species not protected by the Wetlands Protection Act.

** MESA projects may not be segmented (321 CMR 10.16). The applicant must disclose full development plans even if such plans are not required as part of the Notice of Intent process.

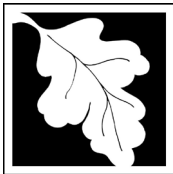

Massachusetts Department of Environmental Protection
Bureau of Resource Protection - Wetlands

WPA Form 3 – Notice of Intent

Massachusetts Wetlands Protection Act M.G.L. c. 131, §40

Provided by MassDEP:

MassDEP File Number

Document Transaction Number

Ashland, MA

City/Town

C. Other Applicable Standards and Requirements (cont'd)

(c) MESA filing fee (fee information available at http://www.mass.gov/dfwele/dfw/nhosp/regulatory_review/mesa/mesa_fee_schedule.htm).
Make check payable to "Commonwealth of Massachusetts - NHESP" and **mail to NHESP** at above address

Projects altering 10 or more acres of land, also submit:

(d) Vegetation cover type map of site

(e) Project plans showing Priority & Estimated Habitat boundaries

(f) OR Check One of the Following

1. Project is exempt from MESA review.
Attach applicant letter indicating which MESA exemption applies. (See 321 CMR 10.14, http://www.mass.gov/dfwele/dfw/nhosp/regulatory_review/mesa/mesa_exemptions.htm; the NOI must still be sent to NHESP if the project is within estimated habitat pursuant to 310 CMR 10.37 and 10.59.)

2. Separate MESA review ongoing. a. NHESP Tracking # _____ b. Date submitted to NHESP _____

3. Separate MESA review completed.
Include copy of NHESP "no Take" determination or valid Conservation & Management Permit with approved plan.

3. For coastal projects only, is any portion of the proposed project located below the mean high water line or in a fish run?

a. Not applicable – project is in inland resource area only b. Yes No

If yes, include proof of mailing, hand delivery, or electronic delivery of NOI to either:

South Shore - Cohasset to Rhode Island border, and the Cape & Islands:

Division of Marine Fisheries -
Southeast Marine Fisheries Station
Attn: Environmental Reviewer
836 South Rodney French Blvd.
New Bedford, MA 02744
Email: DMF.EnvReview-South@state.ma.us

North Shore - Hull to New Hampshire border:

Division of Marine Fisheries -
North Shore Office
Attn: Environmental Reviewer
30 Emerson Avenue
Gloucester, MA 01930
Email: DMF.EnvReview-North@state.ma.us

Also if yes, the project may require a Chapter 91 license. For coastal towns in the Northeast Region, please contact MassDEP's Boston Office. For coastal towns in the Southeast Region, please contact MassDEP's Southeast Regional Office.

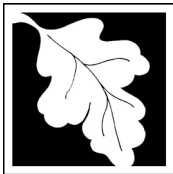

Massachusetts Department of Environmental Protection
Bureau of Resource Protection - Wetlands

WPA Form 3 – Notice of Intent

Massachusetts Wetlands Protection Act M.G.L. c. 131, §40

Provided by MassDEP:

MassDEP File Number

Document Transaction Number

Ashland, MA

City/Town

C. Other Applicable Standards and Requirements (cont'd)

Online Users:
Include your document transaction number (provided on your receipt page) with all supplementary information you submit to the Department.

- 4. Is any portion of the proposed project within an Area of Critical Environmental Concern (ACEC)?
 a. Yes No If yes, provide name of ACEC (see instructions to WPA Form 3 or MassDEP Website for ACEC locations). **Note:** electronic filers click on Website.
 b. ACEC

- 5. Is any portion of the proposed project within an area designated as an Outstanding Resource Water (ORW) as designated in the Massachusetts Surface Water Quality Standards, 314 CMR 4.00?
 a. Yes No
- 6. Is any portion of the site subject to a Wetlands Restriction Order under the Inland Wetlands Restriction Act (M.G.L. c. 131, § 40A) or the Coastal Wetlands Restriction Act (M.G.L. c. 130, § 105)?
 a. Yes No
- 7. Is this project subject to provisions of the MassDEP Stormwater Management Standards?
 a. Yes. Attach a copy of the Stormwater Report as required by the Stormwater Management Standards per 310 CMR 10.05(6)(k)-(q) and check if:
 - 1. Applying for Low Impact Development (LID) site design credits (as described in Stormwater Management Handbook Vol. 2, Chapter 3)
 - 2. A portion of the site constitutes redevelopment
 - 3. Proprietary BMPs are included in the Stormwater Management System.
 b. No. Check why the project is exempt:
 - 1. Single-family house
 - 2. Emergency road repair
 - 3. Small Residential Subdivision (less than or equal to 4 single-family houses or less than or equal to 4 units in multi-family housing project) with no discharge to Critical Areas.

D. Additional Information

- This is a proposal for an Ecological Restoration Limited Project. Skip Section D and complete Appendix A: Ecological Restoration Notice of Intent – Minimum Required Documents (310 CMR 10.12).

Applicants must include the following with this Notice of Intent (NOI). See instructions for details.

Online Users: Attach the document transaction number (provided on your receipt page) for any of the following information you submit to the Department.

- 1. USGS or other map of the area (along with a narrative description, if necessary) containing sufficient information for the Conservation Commission and the Department to locate the site. (Electronic filers may omit this item.)
- 2. Plans identifying the location of proposed activities (including activities proposed to serve as a Bordering Vegetated Wetland [BVW] replication area or other mitigating measure) relative to the boundaries of each affected resource area.

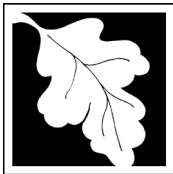

Massachusetts Department of Environmental Protection
Bureau of Resource Protection - Wetlands

WPA Form 3 – Notice of Intent

Massachusetts Wetlands Protection Act M.G.L. c. 131, §40

Provided by MassDEP:

MassDEP File Number

Document Transaction Number

Ashland, MA

City/Town

D. Additional Information (cont'd)

3. Identify the method for BVW and other resource area boundary delineations (MassDEP BVW Field Data Form(s), Determination of Applicability, Order of Resource Area Delineation, etc.), and attach documentation of the methodology.

4. List the titles and dates for all plans and other materials submitted with this NOI.

Sudbury River Access Facility

a. Plan Title

Comprehensive Environmental, Inc.

b. Prepared By

Matthew Lundsted, PE

c. Signed and Stamped by

1"=30'

d. Final Revision Date

e. Scale

f. Additional Plan or Document Title

g. Date

5. If there is more than one property owner, please attach a list of these property owners not listed on this form.

6. Attach proof of mailing for Natural Heritage and Endangered Species Program, if needed.

7. Attach proof of mailing for Massachusetts Division of Marine Fisheries, if needed.

8. Attach NOI Wetland Fee Transmittal Form

9. Attach Stormwater Report, if needed.

E. Fees

1. Fee Exempt: No filing fee shall be assessed for projects of any city, town, county, or district of the Commonwealth, federally recognized Indian tribe housing authority, municipal housing authority, or the Massachusetts Bay Transportation Authority.

Applicants must submit the following information (in addition to pages 1 and 2 of the NOI Wetland Fee Transmittal Form) to confirm fee payment:

26802

2. Municipal Check Number

26804

4. State Check Number

Comprehensive Environmental Inc.

6. Payor name on check: First Name

3/15/2022

3. Check date

3/15/2022

5. Check date

7. Payor name on check: Last Name



Massachusetts Department of Environmental Protection
 Bureau of Resource Protection - Wetlands
NOI Wetland Fee Transmittal Form
 Massachusetts Wetlands Protection Act M.G.L. c. 131, §40

Important: When filling out forms on the computer, use only the tab key to move your cursor - do not use the return key.

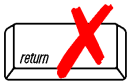

A. Applicant Information

1. Location of Project:

0 Aikens Raod Ashland
 a. Street Address b. City/Town
 \$
 c. Check number d. Fee amount

2. Applicant Mailing Address:

Douglas Cameron
 a. First Name b. Last Name
 Office of Fishing and Boating Access
 c. Organization
 1 Rabbit Hill Road
 d. Mailing Address
 Westborough MA 01581
 e. City/Town f. State g. Zip Code
 617-828-3532 508-389-7890 doug.cameron@mass.gov
 h. Phone Number i. Fax Number j. Email Address

3. Property Owner (if different):

a. First Name b. Last Name
 Commonwealth of Massachusetts
 c. Organization
 100 Cambridge Street
 d. Mailing Address
 Boston MA 02110
 e. City/Town f. State g. Zip Code
 h. Phone Number i. Fax Number j. Email Address

B. Fees

Fee should be calculated using the following process & worksheet. **Please see Instructions before filling out worksheet.**

Step 1/Type of Activity: Describe each type of activity that will occur in wetland resource area and buffer zone.

Step 2/Number of Activities: Identify the number of each type of activity.

Step 3/Individual Activity Fee: Identify each activity fee from the six project categories listed in the instructions.

Step 4/Subtotal Activity Fee: Multiply the number of activities (identified in Step 2) times the fee per category (identified in Step 3) to reach a subtotal fee amount. Note: If any of these activities are in a Riverfront Area in addition to another Resource Area or the Buffer Zone, the fee per activity should be multiplied by 1.5 and then added to the subtotal amount.

Step 5/Total Project Fee: Determine the total project fee by adding the subtotal amounts from Step 4.

Step 6/Fee Payments: To calculate the state share of the fee, divide the total fee in half and subtract \$12.50. To calculate the city/town share of the fee, divide the total fee in half and add \$12.50.

To calculate filing fees, refer to the category fee list and examples in the instructions for filling out WPA Form 3 (Notice of Intent).



Massachusetts Department of Environmental Protection
 Bureau of Resource Protection - Wetlands
NOI Wetland Fee Transmittal Form
 Massachusetts Wetlands Protection Act M.G.L. c. 131, §40

B. Fees (continued)

Step 1/Type of Activity	Step 2/Number of Activities	Step 3/Individual Activity Fee	Step 4/Subtotal Activity Fee
Sudbury River Access Facility	1	\$500	\$750
_____	_____	_____	_____
_____	_____	_____	_____
_____	_____	_____	_____
_____	_____	_____	_____
_____	_____	_____	_____
_____	_____	_____	_____
_____	_____	_____	_____
Step 5/Total Project Fee:			\$750
Step 6/Fee Payments:			
Total Project Fee:			\$750
State share of filing Fee:			\$362.50
City/Town share of filing Fee:			\$387.50
			a. Total Fee from Step 5
			b. 1/2 Total Fee less \$12.50
			c. 1/2 Total Fee plus \$12.50

C. Submittal Requirements

- a.) Complete pages 1 and 2 and send with a check or money order for the state share of the fee, payable to the Commonwealth of Massachusetts.

Department of Environmental Protection
 Box 4062
 Boston, MA 02211

- b.) **To the Conservation Commission:** Send the Notice of Intent or Abbreviated Notice of Intent; a **copy** of this form; and the city/town fee payment.

To MassDEP Regional Office (see Instructions): Send a copy of the Notice of Intent or Abbreviated Notice of Intent; a **copy** of this form; and a **copy** of the state fee payment. (E-filers of Notices of Intent may submit these electronically.)



Massachusetts Department of Environmental Protection
Bureau of Resource Protection - Wetlands

WPA Form 3 – Notice of Intent

Massachusetts Wetlands Protection Act M.G.L. c. 131, §40

Provided by MassDEP:

MassDEP File Number

Document Transaction Number

Ashland, MA

City/Town

F. Signatures and Submittal Requirements

I hereby certify under the penalties of perjury that the foregoing Notice of Intent and accompanying plans, documents, and supporting data are true and complete to the best of my knowledge. I understand that the Conservation Commission will place notification of this Notice in a local newspaper at the expense of the applicant in accordance with the wetlands regulations, 310 CMR 10.05(5)(a).

I further certify under penalties of perjury that all abutters were notified of this application, pursuant to the requirements of M.G.L. c. 131, § 40. Notice must be made by Certificate of Mailing or in writing by hand delivery or certified mail (return receipt requested) to all abutters within 100 feet of the property line of the project location.

<i>Douglas H. Cameron</i>	2-24-2022
1. Signature of Applicant	2. Date
<i>[Signature]</i>	<i>2/24/22</i>
3. Signature of Property Owner (if different)	4. Date
<i>Patricia Huckery</i>	2/2/2022
5. Signature of Representative (if any)	6. Date
<i>[Signature]</i>	

For Conservation Commission:

Two copies of the completed Notice of Intent (Form 3), including supporting plans and documents, two copies of the NOI Wetland Fee Transmittal Form, and the city/town fee payment, to the Conservation Commission by certified mail or hand delivery.

For MassDEP:

One copy of the completed Notice of Intent (Form 3), including supporting plans and documents, one copy of the NOI Wetland Fee Transmittal Form, and a copy of the state fee payment to the MassDEP Regional Office (see Instructions) by certified mail or hand delivery.

Other:

If the applicant has checked the "yes" box in any part of Section C, Item 3, above, refer to that section and the Instructions for additional submittal requirements.

The original and copies must be sent simultaneously. Failure by the applicant to send copies in a timely manner may result in dismissal of the Notice of Intent.

1.0 INTRODUCTION

The Division of Fisheries and Wildlife, in conjunction with the Commonwealth of Massachusetts Department of Fish and Game - Office of Fishing and Boating Access (OFBA), proposes to construct public access improvements to the Sudbury River along Aikens Road in Ashland, MA. Proposed improvements include a new accessible shoreline fishing area, kayak/canoe launch, and designated parking area.

Aikens Road is a dirt/gravel road that runs parallel to the Sudbury River. Most of the riverfront area between Aikens Road and the Sudbury River consists of undeveloped woodlands. The general public usually accesses the river through these woodlands to fish and engage in other recreational activities.

1.1 Project Location and Property Owners

The proposed project is located along Aikens Road and the southern shoreline of the Sudbury River (see locus map, **Appendix A**). The project will take place entirely within property owned by the Commonwealth of Massachusetts. The project extents and property lines are shown on the design plans provided in **Appendix H**. Refer to **Table 1** below for the parcel information.

Table 1 – Parcel Information			
Property Address	Owner Name	Owner Mailing Address	Parcel ID
Aikens Road (0 Rock Street Abandoned)	Commonwealth of Massachusetts	100 Cambridge Street, Boston, MA 02110	0140060000100000

2.0 DESCRIPTION OF PROPOSED WORK

2.1 Existing Conditions

The project area currently consists of predominantly woodland vegetation with some minor clearings. There are also numerous boulders and bedrock outcrops surrounding both sides of Aikens Road. Most of the land is undeveloped except for one property at the beginning of Aikens Road, and several properties on Aikens Road approximately 0.2 miles to the east of the project site. To the south of Aikens Road, there are stone walls that delineate property boundaries.

An existing conditions survey and site reconnaissance was completed by Comprehensive Environmental Inc. (CEI) in March 2021, which included wetland delineation and survey of 1-foot contours for the project area. Four benchmarks were created during CEI’s ground survey through the use of a RTK GPS system. Stakes were driven into the ground to mark out each benchmark.

Refer to **Appendix B** for Site Photos of the existing conditions.

2.1.1 Wetland Delineation

CEI conducted a wetland delineation at the project site on March 24, 2020. The wetland boundary was flagged according to the methodology described in *Delineating Bordering Vegetated Wetlands Under the Massachusetts Wetlands Protection Act* (MassDEP, 1995). The wetland boundary was flagged with pink wetland flagging in most locations, with wire flagging stakes used in several locations where woody vegetation was not present.

Wetland resource areas in the vicinity of the proposed project were delineated with wetland flags A1 to A20. Although most of this delineation marks the Bordering Vegetated Wetlands (BVW) boundary adjacent to the Sudbury River, several areas were a Bank delineation, including flags A9 to A12 which are adjacent to the proposed fishing access area and kayak/canoe launch.

BVW areas adjacent to the Sudbury River included a variety of herbaceous wetland species, such as reed canary grass (*Phalaris arundinacea*), tussock sedge (*Carex stricta*), cinnamon fern (*Osmunda cinnamomea*), sensitive fern (*Onoclea sensibilis*), skunk cabbage (*Symplocarpus foetidus*). Shrub species included sweet pepperbush (*Clethra alnifolia*), speckled alder (*Alnus rugosa*), and gray dogwood (*Cornus racemosa*). Red maple (*Acer rubrum*) and white pine (*Pinus strobus*) were the most common tree species within the wetland and at the wetland/upland boundary.

2.2 Proposed Conditions

Prior to the start of construction activities, temporary erosion controls, and surface water/groundwater control systems will be installed as shown on Sheet C-2 of the design plans. Temporary working areas and proposed design footprint areas will then be excavated to install specified subgrade materials.

Once excavation activities are completed, the construction of the proposed parking area, gravel access path, designated fishing area, and canoe/kayak launch can begin. The proposed parking area will be constructed along the southern shoulder of Aikens Road. The parking area will have 5 parallel parking spots with signage. The parking area will be constructed using a 6-inch-thick layer of dense graded crushed stone over a 6-inch-thick layer of compacted roadway gravel. In order to install the designated parking area at proposed grades, a small concrete retaining wall will be installed. The retaining wall will be 3-feet exposed, 1-foot wide, and approximately 45-feet long. A 3-foot-wide infiltration trench will line the southern side of the parking area to capture stormwater runoff and associated sediment. The infiltration trench will consist of 3-inch crushed stone that drains to a filter fabric lined trench of 1.5-inch washed crush stone.

A 6-foot-wide gravel access path will be installed across from the parking area on the northern side of Aikens Road. At the end of the gravel path, a designated fishing area and canoe/kayak launch will be installed.

The fishing area will consist of packed flat crushed stone surrounded by granite curbing. The canoe/kayak launch will be installed on the shoreline of the Sudbury River and will consist of a gravel ramp at a slope of 4.0% that matches existing grades, and a 6' by 6' poured concrete pad between EL: 233' and 230' at a constructed slope of 15.7% to the water's edge.

After installation of subgrade materials and proposed designs, final site stabilization and proposed grading will take place. Stabilization of all disturbed areas will be achieved with native seed mixtures. These disturbed areas can be seen on Sheet P-2 of the design plans in **Appendix H**.

The limits of work are shown on the design plans. Equipment and material staging areas will be located upland during construction and proper sediment and erosion controls will be implemented such as turbidity curtains, compost filter tubes, and silt sacks around the excavation areas. Construction access to the site will be via Aikens Road, and staging areas shall be set-up as designated on the design plans, upland from the bank within riverfront area. Disturbed areas will be returned to pre-construction condition or better.

3.0 PROPOSED RESOURCE AREA IMPACTS AND MITIGATION

Proposed temporary and permanent impacts to wetland resource areas and associated buffer zones are summarized in Table 2 and described in the sections that follow.

According to the NHESP’s online mapping system, the project limits do not fall within areas considered to be Estimated Habitats of Rare Wildlife or Priority Habitats of Rare Species. Refer to **Appendix D** for the NHESP Map.

Table 2: Proposed Resource Area Impacts		
Resource Area	Temporary Impact	Permanent Impact
Bank	49 LF	12 LF
Bordering Vegetated Wetlands	653 SF	0 SF
Land Under Water and Waterbodies	0 SF	0 SF
Bordering Land Subject to Flooding	1,900 SF	200 SF
Riverfront Area (200’ Buffer)	4,911 SF	4,488 SF
25-foot No-Disturb Zone (Ashland Wetland Protection Regulations)	4,235 SF	756 SF

3.1 Bank (310 CMR 10.54)

61 linear feet of impact to Bank is associated with the construction of the proposed fishing access area and canoe/kayak launch:

- 49 linear feet of impact associated with the fishing access area will be temporary, with minor proposed changes to grading. All disturbed areas will be stabilized with erosion control mat and re-vegetated with an appropriate seed mix for slope stabilization (New England Erosion Control/Restoration Mix for Detention Basins and Moist Sites).

Materials supplied for the proposed vegetated bank stabilization be required to include source certification that they do not contain invasive species/seeds or come from a source known to be adjacent to such species.

- 12 linear feet of permanent impact to Bank are associated with construction of the canoe/kayak launch.

The design meets all of the performance standards required in 310 CMR 10.54 4(a)(b).

3.2 Bordering Vegetated Wetlands (310 CMR 10.55) and Buffer Zone

No permanent impacts to BVW are proposed. 1,900 square feet of temporary impacts to BVW are proposed, which are associated with temporary disturbance to vegetation and soils during construction. All areas of temporary impact to BVW will be restored in place by seeding with the New England Wetmix seed mixture from New England Wetland Plants Inc. (NEWP). All BVW restoration areas will be raked prior to seeding to restore any areas of compaction and to ensure good soil/seed contact. All seeded areas will be stabilized with a weed free straw mulch. Erosion and sedimentation controls will be used during construction to minimize the impacts to the adjacent resource areas.

This design complies with the performance standards required within 310 CMR 10.55

3.3 Land Under Waterbodies (310 CMR 10.56)

There are no proposed temporary or permanent impacts to land under waterbodies.

3.4 Bordering Land Subject to Flooding (310 CMR 10.57)

The 100-year floodplain is at elevation 234', according to the FIRM map provided in **Appendix C**. The proposed fishing platform and kayak/canoe launch will occur within BLSF between elevations 230' to 234' and therefore the project requires a Cut/Fill analysis be performed at each individual impacted contour interval. See **Table 3** below for a summary of cut and fill volumes at each 1-foot contour interval within the 100-year floodplain.

Table 3 – Cut / Fill Analysis Summary			
<i>Contour Interval</i>	<i>Cut</i>	<i>Fill</i>	<i>Net*</i>
El. 230 – 231	0 CF	91 CF	91 CF
El. 231 – 232	-8 CF	97 CF	89 CF
El. 232 - 233	-2 CF	33 CF	31 CF
El. 233 – 234	-8 CF	0 CF	-8 CF
El. 234 – 235	-346 CF	0 CF	-346 CF
			-143 CF

* Negative numbers represent net cut values.

Compensatory storage will be required for this project since the cut/fill analysis resulted in net fill in three of the 1-foot contour intervals within the BLSF (100-year floodplain is at elevation 234', according to the FIRM map provided in **Appendix C**). From El. 230-231 there is a net fill of 91 CF, from El. 231-232 there is a net fill of 89 CF, and from El. 232-233 there is a net fill of 31 CF. The proposed compensatory flood storage design is available on Sheet P-1 of the Permit Plans in **Appendix J**.

The total area of permanent BLSF impacts is 200 square feet, which is less than the 5,000-square foot threshold for being deemed to impair the capacity of the floodplain to provide important wildlife habitat functions. The proposed work will not restrict flows or flood stage velocities. Low-impact foundation elements will be used to minimize flow restriction.

This design complies with the performance standards required within 310 CMR 10.57 4(a).

3.5 100-Foot Buffer Zone

9,399 square feet of impact within the 100-foot Buffer Zone to BVW is proposed.

Areas of temporary Buffer Zone impact will be re-vegetated with a seed mixture that provides both good erosion control and high wildlife habitat value (New England Conservation/Wildlife Mix, NEWP) and will be stabilized during vegetation establishment with a weed-free straw mulch.

3.6 Riverfront Area (310 CMR 10.58)

The work proposed within the Riverfront Area has been designed to have the smallest impervious footprint possible. All work shall adhere to the construction sequence and protective measures outlined in Sections 5.0 and 6.0 to prevent impacts to the Sudbury River.

The design meets the performance standards required within 310 CMR 10.58 4(a-c). An Alternatives Analysis is provided in Section 3.6.

3.7 25-foot No-Disturb Zone (Ashland Wetland Protection Regulations)

The Town of Ashland Wetlands Protection Regulations (Chapter 280 of Ashland Town Code) establishes a 25-foot “No-Disturb Zone” from the border of any wetland resource area and requires Applicants to seek a waiver for proposed activities within this zone.

The proposed project will include 4,991 square feet of impact within the 25-foot No-Disturb Zone. This includes 4,235 square feet of temporary impacts and 756 square feet of permanent impacts. Temporary impacts to this zone will be re-vegetated and stabilized with on-site soils from necessary cuts. Permanent impacts proposed have been designed to provide minimal impervious surface and create no impact on proximate resource areas. This project will serve to create a permanent structure with a formalized parking area for an area that is currently in use for recreation. The fishing access area and boat launch will serve as better access for community members to make use of the Sudbury River.

This section seeks to meet the provisions of Chapter 348 of Ashland Town Code to seek a waiver for work conducted in the 25-foot No-Disturb Zone.

3.8 Alternatives Analysis

Three alternatives for the fishing platform were evaluated:

1. Alternative 1: No action
2. Alternative 2: Stone Access Paths and Fishing Area with Parking located outside of the 200-FT Riverfront Buffer
3. Alternative 3: Stone Access Paths and Fishing Area with Parking

Selection for the proposed design was based on several factors which included minimization of environmental impact, construction and phasing feasibility, structural design requirements, and Americans with Disabilities Act (ADA) standards. The alternative that provided the highest benefits was selected as the proposed alternative.

Alternative 1: No Action

The goal of this project is to improve public access to the Sudbury River with a kayak/canoe launch, shore fishing area, and designated vehicle parking. A “no action” alternative will result in a continuation of limited and informal access to the river. People would still park their cars along the narrow shoulder of Aikens Road, making two-way traffic difficult and increasing erosion along the shoulder. Additionally, foot traffic to the river for fishing and/or canoe/kayaking would continue along informal foot paths, contributing to erosion along the banks of the Sudbury River. Although “no action” would result in no short-term resource area impacts and no cost, the disadvantages outweigh the advantages and the project goal of improved public river access would not be met. This option was not chosen as the most viable option.

Alternative 2: Stone Access Paths and Fishing Area with Parking located outside of the 200-FT Riverfront Buffer

This alternative would address the goal of providing formalized access to the Sudbury River while also providing a designated fishing and parking area. A dense stone access path will extend from Aikens Road to a shoreline fishing area and a canoe/kayak launch. A designated parking area with spaces for 5 vehicles would be constructed along the shoulder of Aikens Road. The parking would be located approximately 550-FT to the east of the proposed access path and fishing area and outside of the 200-ft Riverfront Buffer. Although this would be advantageous from an impact standpoint, it would not meet some of the goals of this project. One of the goals of this project is to provide handicapped access to the fishing area and canoe/kayak launch. To meet ADA/AAB requirements, parking needs to be as close to the access facility as possible. Relocating the parking would require the construction of an accessible path from the alternate parking area to the shore fishing and canoe/kayak launch. This path would need to be a minimum of 6’ wide, with a slope not exceeding 5% and would require clearing and grubbing of existing trees and vegetation and grading. People may also still park as close to the access facility as possible even if parking is provided at another location. The disadvantages of this alternative outweigh the advantages and this option was not chosen as the most viable option.

Alternative 3: Stone Access Path and Fishing Area with Parking

This alternative would address the goal of providing improved and formalized public access to the Sudbury River, including enhanced fishing access and designated parking spaces. A dense stone access path will extend from Aikens Road to a shoreline fishing area and a canoe/kayak launch. A designated parking area with spaces for 5 vehicles will be constructed along the shoulder of Aikens Road directly across from the waterfront access. This alternative eliminates the disadvantages associated with Alternative 2, while providing formalized access to the river, designated parking, and an area for people to fish. This alternative meets all project goals at the most reasonable cost while also minimizing wetland resource area impacts. This option was chosen as the most viable option.

4.0 CONSTRUCTION SEQUENCE

The construction process will generally consist of the following items:

- Mobilization;
- Installation of temporary erosion controls, and surface water/ groundwater control systems;
- Clearing of designated trees and shrubs;
- Construction of temporary staging areas;
- Excavation for proposed parking area, access path, kayak/canoe launch, and fishing area.
- Installation of proposed designs;
- Structure backfilling and grading to proposed grades;
- Site cleanup and demobilization.

Proposed design plans and details are provided in **Appendix H**.

5.0 PROTECTIVE MEASURES

Measures will be taken to minimize erosion/sedimentation into the resource areas and buffer zones during construction. Erosion control during construction will include but is not limited to:

- Erosion control measures will be provided for materials storage areas, staging areas, excavation areas, and in the river directly adjacent to the construction area;
- Construction and material storage activities will be conducted in a manner to control sediment and dust migration;
- Onsite sediment controls will include silt fences/silt socks surrounding proposed designs and along the bank of the Sudbury River;
- Riverine sediment controls will consist of a floating silt boom or turbidity curtain in the Sudbury River set around the project limits;
- Sediment controls will be inspected daily and after each significant rainfall event. Any entrapped silt or other materials will be removed. Silt socks and other devices will be replaced as necessary;
- Sediment control devices will remain in place until disturbed surfaces have been stabilized;
- Contractors will be familiar with oil spill prevention and response measures and spill cleanup materials will be available onsite;
- Construction access will be limited to the Aikens Road to minimize land disturbance;
- All disturbed areas will be stabilized with vegetative cover upon construction completion;
- No temporary fill will be permitted for construction, staging or installation purposes within upper banks or riverfront areas;

6.0 STORMWATER STANDARDS REPORT

Standard 1. No New Untreated Discharges

N/A – Minimal exposed impervious area is proposed, as the proposed fishing area is crushed stone, which will allow runoff infiltrate to the ground below. The kayak/canoe launch proposes 36 sq ft of concrete pad as impervious surface, as well as minor impervious surface created by the addition of granite curbing around the gravel parking area. However, the proposed use and impact of these minimal impervious areas does not preclude treatment prior to discharge. Therefore, no new untreated discharges are expected as a result of this project.

Standard 2. Peak Rate Attenuation

N/A – Minimal exposed impervious area is proposed and all runoff will either seep through and percolate into the ground below or drain to the Sudbury River, similar to pre-existing conditions. Therefore, peak rate attenuation is anticipated to remain the same.

Standard 3. Recharge

N/A – Minimal exposed impervious area is proposed and all runoff will either seep through and percolate into the ground below or drain to the Sudbury River, similar to pre-existing conditions. Therefore, groundwater recharge is anticipated to remain the same.

Standard 4. Water Quality

N/A – This project will have no permanent negative effect on water quality. Temporary impacts will be closely monitored and mitigated in a timely manner.

Standard 5. Land Uses with Higher Potential Pollutant Loads

N/A- The project is not proposing a land use or an area with higher potential pollutant loads.

Standard 6. Critical Areas

N/A – The project does not impact Critical Areas.

Standards 7. Redevelopments and Other Projects Subject to the Standards Only to the Maximum Extent Practicable

This project is a mix of new and redevelopment.

Standard 8. Construction Period Pollution Prevention and Erosion and Sedimentation Control

This project consists of <1 acre of disturbance and therefore is not covered under the Construction General Permit. Erosion and sedimentation measures are discussed in Sections 5.0 and 6.0.

Standard 9. Operations & Maintenance Plan

N/A – No stormwater related facilities are proposed so a Stormwater O&M Plan is not required.

Standard 10. Prohibition of Illicit Discharges

N/A – This project does not include closed drainage infrastructure, therefore there is no potential for illicit discharges.

7.0 PERMISSION LETTERS AND ABUTTER NOTIFICATION

7.1 Permission Letters / Easements

The proposed work will be performed on land owned by the Commonwealth of Massachusetts – Department of Fish and Game (DFG). DFG is a project co-applicant and has provided the required land owner signature (see WPA-Form 3). No additional permission letters are required.

7.2 Abutters

Abutters for this project were defined by the Town of Ashland Assessor’s office, which provided a certified abutter list for the subject property parcel. This certified list identified four abutting parcels. All four property owners were notified in writing as required under Section 11 of Part I, Title VII, Chapter 40A of MGL. Refer to **Appendix F** for a numbered parcel map with lot locations and a corresponding list of abutters. Abutting properties were based on definitions set forth in Chapter 40A. Construction access and all proposed work is being completed within the Riverside Park property owned by the Town. Copies of the abutter letters and certified mail receipts are included in **Appendix G**.

Appendix A
USGS Locus Map



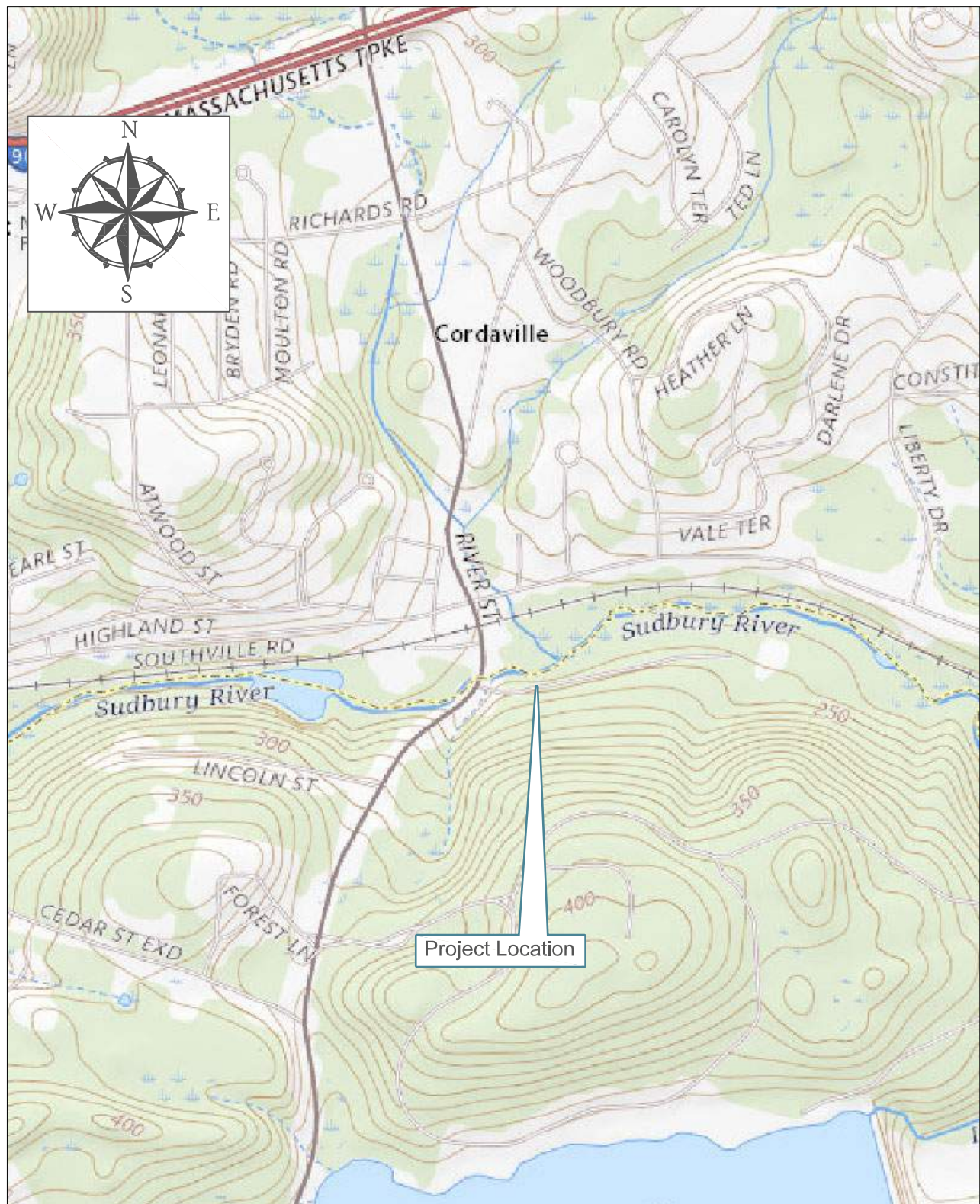

GENERAL NOTES

1. Locus map based on USGS 7.5x7.5 Grid US Topo Map of Ashland, MA from the USGS map webstore:
<http://www.store.usgs.gov>
2. SCALE: 1"=1000'

Figure 1
 USGS Locus Map
 SUDBURY RIVER
 ACCESS FACILITY
 ASHLAND, MA



COMPREHENSIVE ENVIRONMENTAL INCORPORATED

41 MAIN STREET
 BOLTON, MA 01740

Appendix B Site Photographs



Appendix B
Site Photographs



Photograph 1: Facing North towards
Sudbury River, existing berm



Photograph 2: Facing West, left bank of existing
berm on Sudbury River

Appendix B
Site Photographs



Photograph 3: Facing Northeast, approximate location of proposed boat launch off existing berm



Photograph 4: Facing East, right bank of existing berm on Sudbury River, downstream

Appendix C
FEMA Flood Insurance Rate Map (FIRM), Floodway Data,
and Flood Profiles



National Flood Hazard Layer FIRMette



71°31'27"W 42°16'13"N

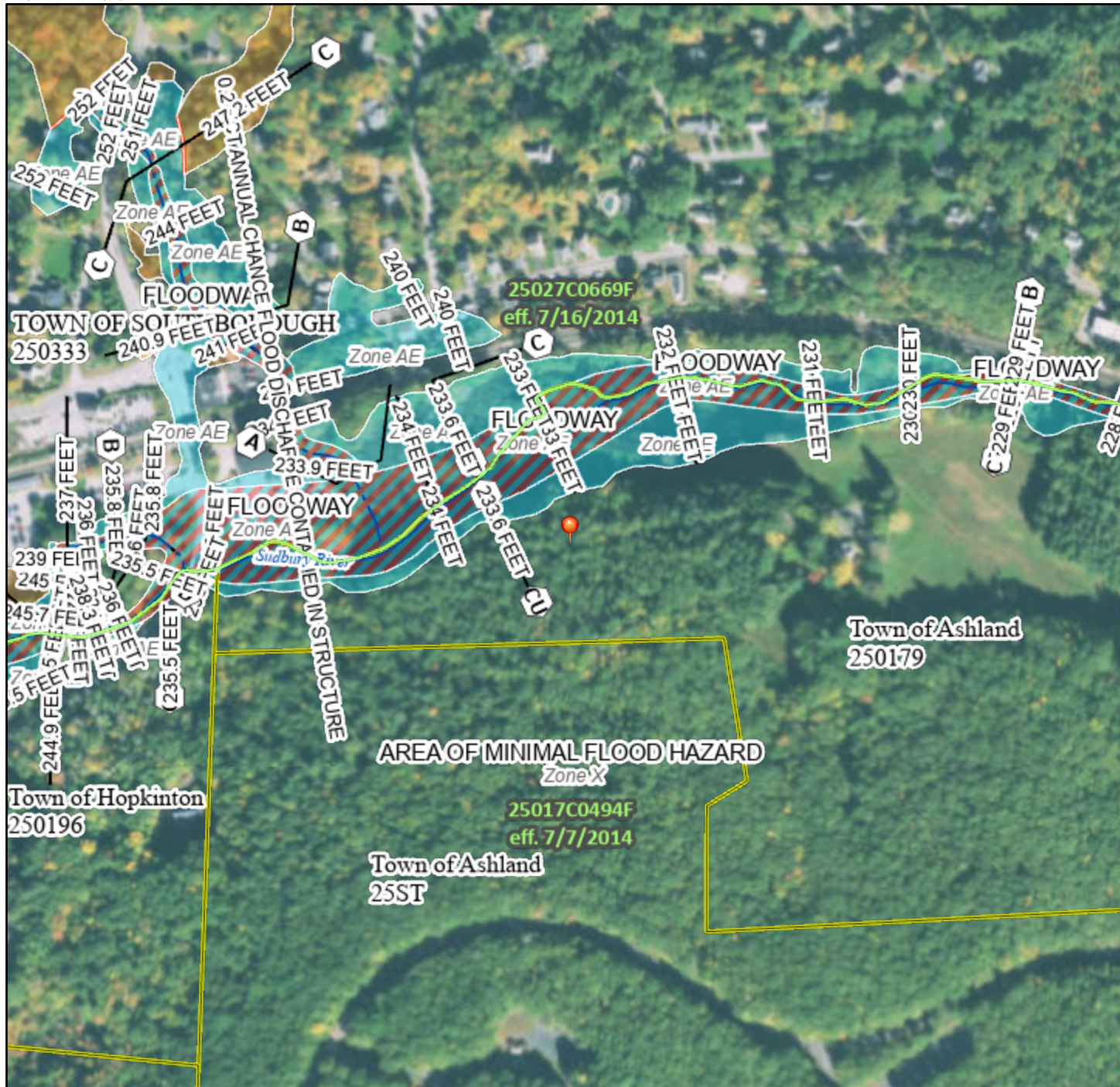

Legend

SEE FIS REPORT FOR DETAILED LEGEND AND INDEX MAP FOR FIRM PANEL LAYOUT

SPECIAL FLOOD HAZARD AREAS		Without Base Flood Elevation (BFE) Zone A, V, A99
		With BFE or Depth Zone AE, AO, AH, VE, AR
		Regulatory Floodway

OTHER AREAS OF FLOOD HAZARD		0.2% Annual Chance Flood Hazard, Areas of 1% annual chance flood with average depth less than one foot or with drainage areas of less than one square mile Zone X
		Future Conditions 1% Annual Chance Flood Hazard Zone X
		Area with Reduced Flood Risk due to Levee. See Notes. Zone X
		Area with Flood Risk due to Levee Zone D

OTHER AREAS		NO SCREEN Area of Minimal Flood Hazard Zone X
		Effective LOMRs
GENERAL STRUCTURES		Area of Undetermined Flood Hazard Zone D
		Channel, Culvert, or Storm Sewer
		Levee, Dike, or Floodwall

OTHER FEATURES		20.2 Cross Sections with 1% Annual Chance Water Surface Elevation
		17.5 Cross Sections with 1% Annual Chance Water Surface Elevation
		Coastal Transect
		Base Flood Elevation Line (BFE)
		Limit of Study
OTHER FEATURES		Jurisdiction Boundary
		Coastal Transect Baseline
		Profile Baseline
		Hydrographic Feature

MAP PANELS		Digital Data Available
		No Digital Data Available
		Unmapped
		The pin displayed on the map is an approximate point selected by the user and does not represent an authoritative property location.

This map complies with FEMA's standards for the use of digital flood maps if it is not void as described below. The basemap shown complies with FEMA's basemap accuracy standards





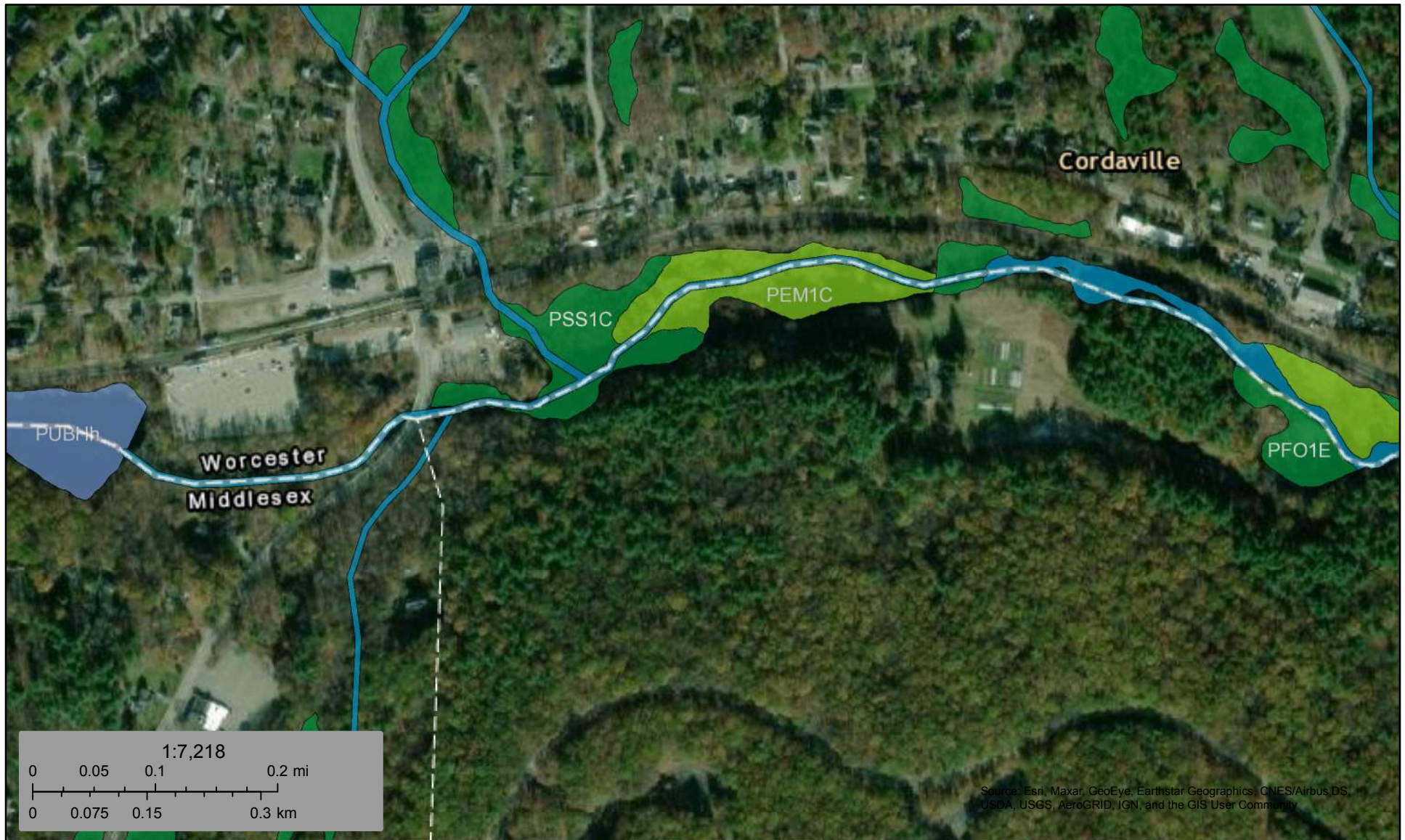

The flood hazard information is derived directly from the authoritative NFHL web services provided by FEMA. This map was exported on 6/4/2021 at 11:50 AM and does not reflect changes or amendments subsequent to this date and time. The NFHL and effective information may change or become superseded by new data over time.

This map image is void if the one or more of the following map elements do not appear: basemap imagery, flood zone labels, legend, scale bar, map creation date, community identifiers, FIRM panel number, and FIRM effective date. Map images for unmapped and unmodernized areas cannot be used for regulatory purposes.



June 4, 2021

Wetlands

- | | | | | | |
|---|--------------------------------|---|-----------------------------------|---|----------|
|  | Estuarine and Marine Deepwater |  | Freshwater Emergent Wetland |  | Lake |
|  | Estuarine and Marine Wetland |  | Freshwater Forested/Shrub Wetland |  | Other |
| | |  | Freshwater Pond |  | Riverine |

This map is for general reference only. The US Fish and Wildlife Service is not responsible for the accuracy or currentness of the base data shown on this map. All wetlands related data should be used in accordance with the layer metadata found on the Wetlands Mapper web site.

Appendix D
Natural Heritage & Endangered Species Program
(NHESP) Map



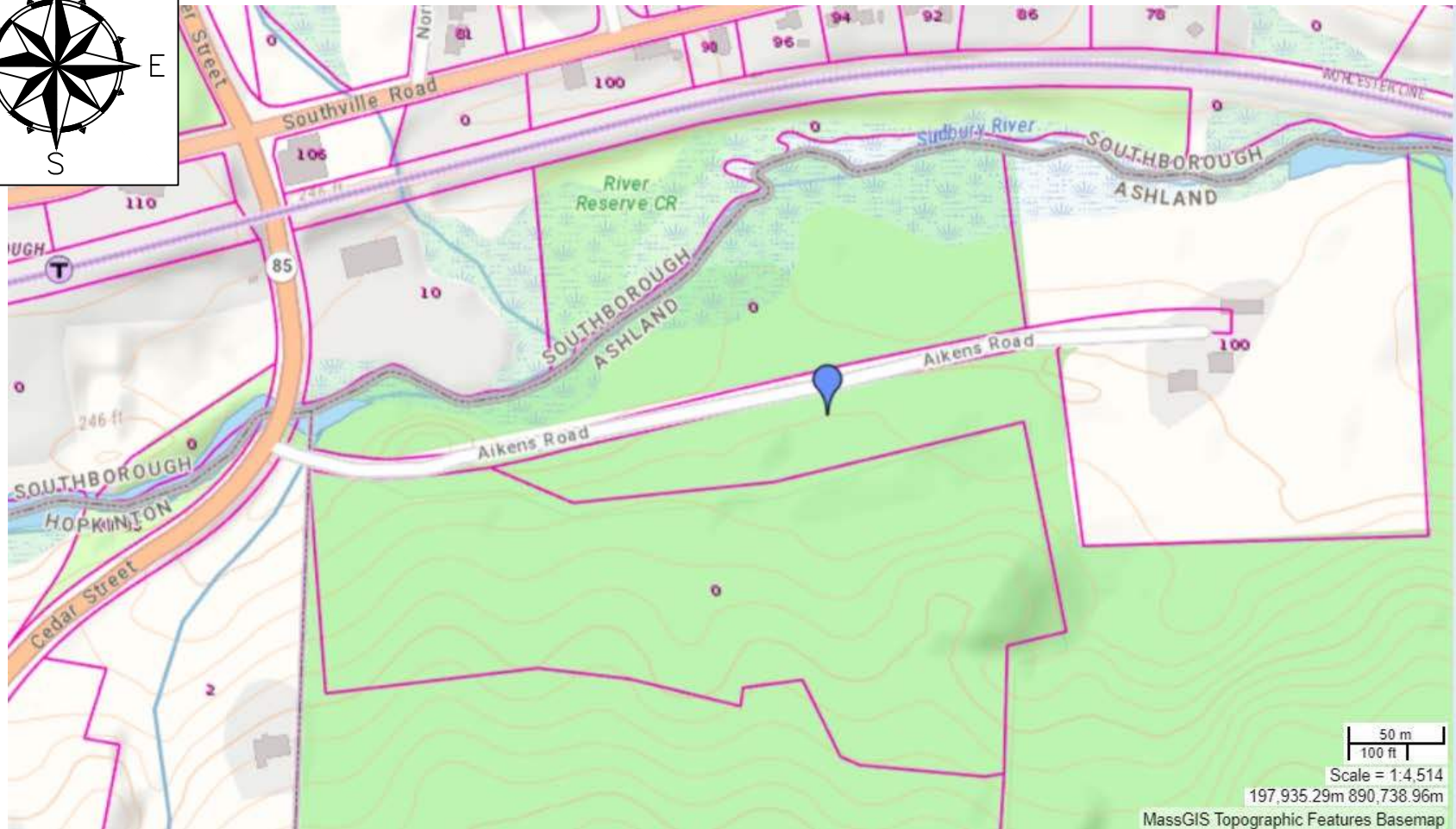
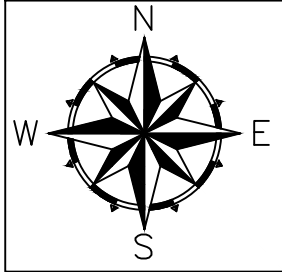

Legend

Potential Vernal Pools



NHESP Certified Vernal Pools



NHESP Priority Habitats of Rare Species



NHESP Estimated Habitats of Rare Wildlife



NHESP MAP SUDBURY RIVER ACCESS ASHLAND MA

Aikens Road

Division of Fish and Wildlife

OLIVER.maps.massgis.state.ma.us



COMPREHENSIVE ENVIRONMENTAL INCORPORATED

41 MAIN STREET
BOLTON, MA 01740

Appendix E

Soils Map



Soil Map—Middlesex County, Massachusetts; and Worcester County, Massachusetts, Northeastern Part

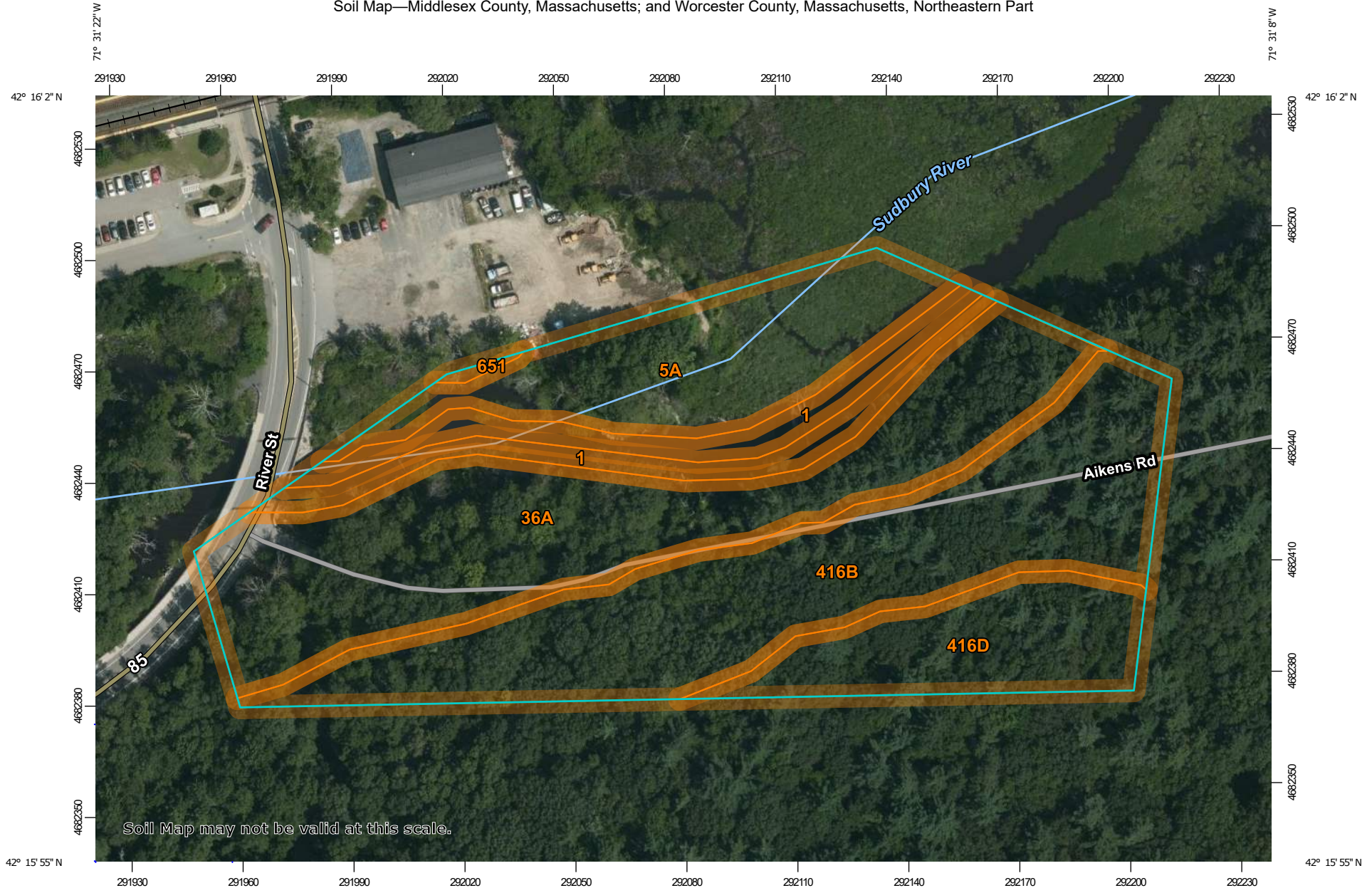

Map Scale: 1:1,450 if printed on A landscape (11" x 8.5") sheet.

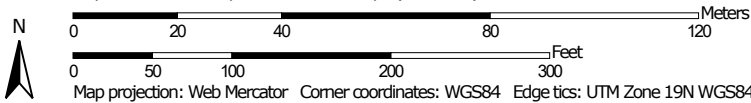



MAP LEGEND



















Area of Interest (AOI)







Area of Interest (AOI)

Soils

-  Soil Map Unit Polygons
-  Soil Map Unit Lines
-  Soil Map Unit Points

Special Point Features





-  Blowout
-  Borrow Pit
-  Clay Spot
-  Closed Depression
-  Gravel Pit
-  Gravelly Spot
-  Landfill
-  Lava Flow
-  Marsh or swamp
-  Mine or Quarry
-  Miscellaneous Water
-  Perennial Water
-  Rock Outcrop
-  Saline Spot
-  Sandy Spot
-  Severely Eroded Spot
-  Sinkhole
-  Slide or Slip
-  Sodic Spot

-  Spoil Area
-  Stony Spot
-  Very Stony Spot
-  Wet Spot
-  Other
-  Special Line Features

Water Features

-  Streams and Canals

Transportation

-  Rails
-  Interstate Highways
-  US Routes
-  Major Roads
-  Local Roads

Background

-  Aerial Photography

MAP INFORMATION

The soil surveys that comprise your AOI were mapped at scales ranging from 1:20,000 to 1:25,000.

Warning: Soil Map may not be valid at this scale.

Enlargement of maps beyond the scale of mapping can cause misunderstanding of the detail of mapping and accuracy of soil line placement. The maps do not show the small areas of contrasting soils that could have been shown at a more detailed scale.

Please rely on the bar scale on each map sheet for map measurements.

Source of Map: Natural Resources Conservation Service
 Web Soil Survey URL:
 Coordinate System: Web Mercator (EPSG:3857)

Maps from the Web Soil Survey are based on the Web Mercator projection, which preserves direction and shape but distorts distance and area. A projection that preserves area, such as the Albers equal-area conic projection, should be used if more accurate calculations of distance or area are required.

This product is generated from the USDA-NRCS certified data as of the version date(s) listed below.

Soil Survey Area: Middlesex County, Massachusetts
 Survey Area Data: Version 20, Jun 9, 2020

Soil Survey Area: Worcester County, Massachusetts,
 Northeastern Part
 Survey Area Data: Version 15, Jun 10, 2020

Your area of interest (AOI) includes more than one soil survey area. These survey areas may have been mapped at different scales, with a different land use in mind, at different times, or at different levels of detail. This may result in map unit symbols, soil properties, and interpretations that do not completely agree across soil survey area boundaries.

Soil map units are labeled (as space allows) for map scales 1:50,000 or larger.

Date(s) aerial images were photographed: Jul 28, 2019—Aug 15, 2019

MAP LEGEND

MAP INFORMATION

The orthophoto or other base map on which the soil lines were compiled and digitized probably differs from the background imagery displayed on these maps. As a result, some minor shifting of map unit boundaries may be evident.

Map Unit Legend

Map Unit Symbol	Map Unit Name	Acres in AOI	Percent of AOI
1	Water	0.3	4.8%
36A	Saco mucky silt loam, 0 to 1 percent slopes	1.9	31.3%
416B	Narragansett silt loam, 3 to 8 percent slopes, very stony	1.9	31.6%
416D	Narragansett silt loam, 15 to 25 percent slopes, very stony	0.7	11.0%
Subtotals for Soil Survey Area		4.7	78.8%
Totals for Area of Interest		6.0	100.0%

Map Unit Symbol	Map Unit Name	Acres in AOI	Percent of AOI
1	Water	0.3	5.3%
5A	Saco silt loam, 0 to 3 percent slopes	0.9	15.6%
651	Udorthents, smoothed	0.0	0.2%
Subtotals for Soil Survey Area		1.3	21.2%
Totals for Area of Interest		6.0	100.0%

Appendix F
Parcel Map and Certified Abutter List





- LEGEND**
- GPOD
 - ADD A
 - POND ST OVERLAY DISTRICT
 - SOLAR OVERLAY
 - ASSESSOR MAP GRID
 - EASEMENT
 - BUILDINGS
 - TRAIN LINE
 - TRAIN RIGHT OF WAY
 - WATER BODIES
 - TAX PARCELS
- ZONING DISTRICTS**
- RESIDENTIAL**
- RESIDENTIAL A
 - RESIDENTIAL B
 - RESIDENTIAL MULTI-FAMILY
- COMMERCIAL**
- ADD B
 - ADD C
 - DOWNTOWN COMMERCE
 - HIGHWAY COMMERCE
 - OFFICE COMMERCE
 - VILLAGE COMMERCE
 - NEIGHBORHOOD COMMERCE
- INDUSTRIAL**
- I
- RAIL TRANSIT DISTRICT**
- RTD A
 - RTD B
 - RTD C
 - RTD D
 - RTD E
 - RTD F
- WILDWOOD MIXED USE DISTRICT**
- WMUSD A
 - WMUSD B
 - WMUSD C
 - WMUSD D
 - WMUSD E
 - WMUSD BUFFER
- OTHER**
- QUARRY REMEDIATION
 - RAIL RIGHT OF WAY

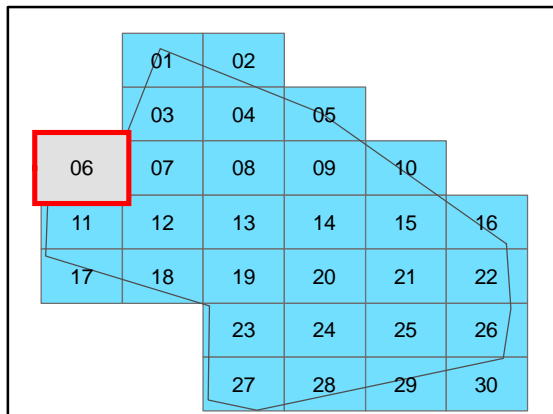
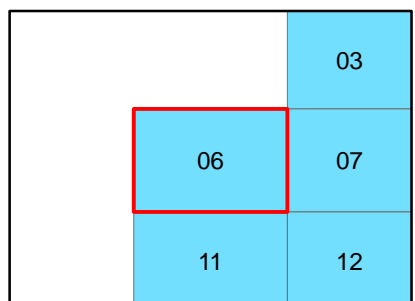

Date: 9/6/2017

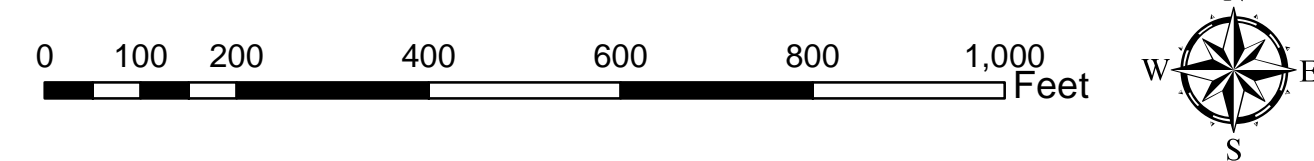
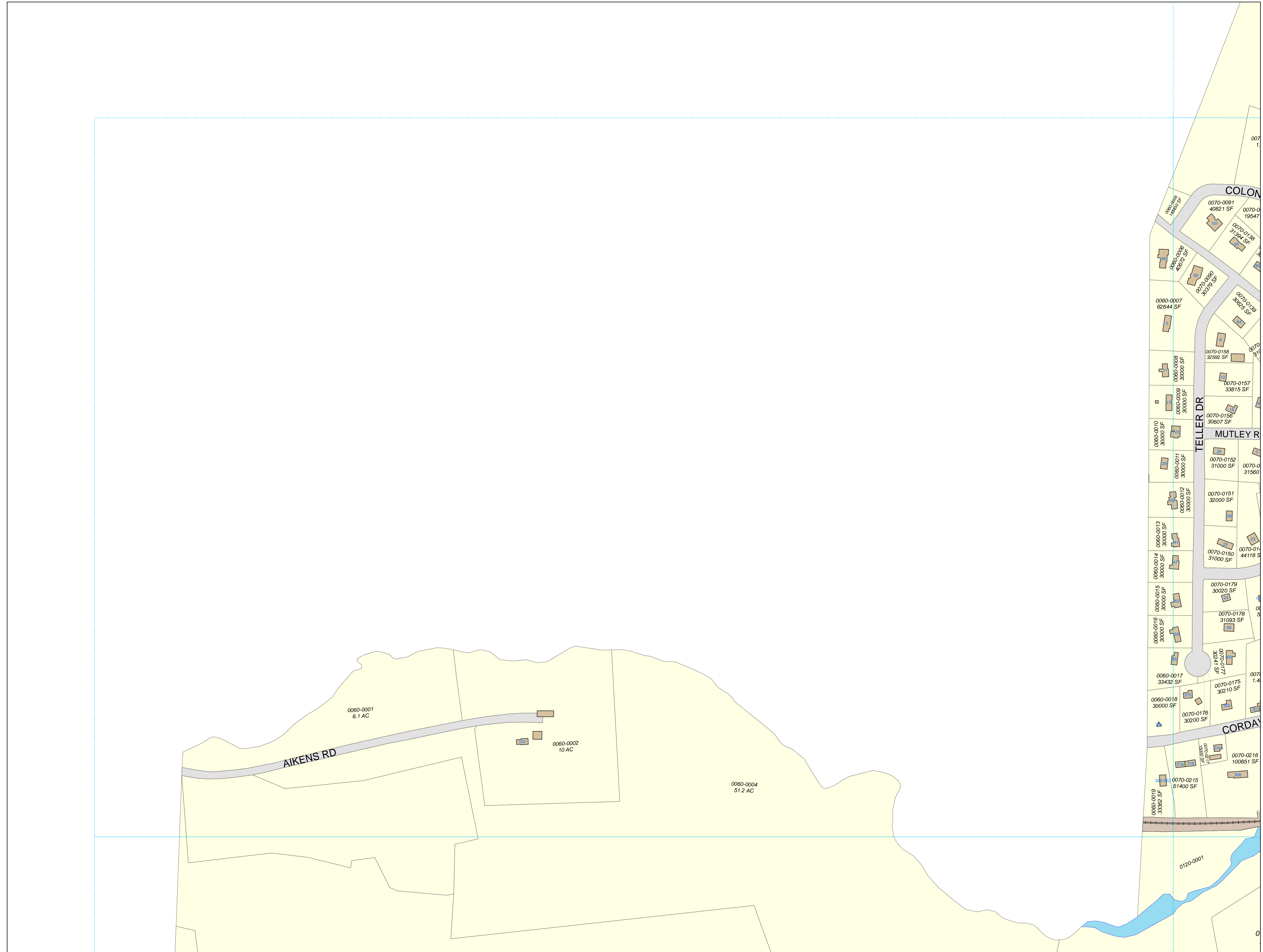

TOWN OF ASHLAND - 2017 ZONING ATLAS

Information shown on this map is from the Ashland GIS database. The Town of Ashland does not guarantee the accuracy of the information. Users are responsible for determining its suitability for their intended use or purpose. Parcel lines depict approximate boundaries of land ownership and should not be used to support any legal determination of boundaries related to rights or interests in real property. Easements shown are approximate and the information is incomplete.

Parcel data conforms to MassGIS Level 3 Standards

August 2, 2021

To The Conservation Commission
0 Rock Street Abandoned
(Aikens Road)
Commonwealth of MA
Division of Fisheries Wildlife

PARCEL ID	PARCEL LOCATION	OWNER NAME 1	OWNER NAME 2	MAILING ADDRESS	CITY/TOWN	STATE	ZIP
06-002-00-000	100 AIKENS RD	CROWLEY ANN		PO BOX 284	ASHLAND	MA	01721
06-003-00-000	0 ROCK ST-ABANDONED	DEPT OF ENVIRONMENTAL MANAGEMENT	(MASS COMMONWEALTH DNR)	251 CAUSEWAY ST / SUITE 600 - 700	BOSTON	MA	02114
06-004-00-000	0 HOWE ST	COMM OF MASS	DIV FISHERIES & WILDLIFE	100 CAMBRIDGE ST	BOSTON	MA	02114
11-013-00-000	0 HOWE ST	DEPT OF ENVIRONMENTAL MANAGEMENT	(MASS COMMONWEALTH DNR)	251 CAUSE WAY ST / SUITE 600 - 700	BOSTON	MA	02114

The above reflects the latest information available on our records

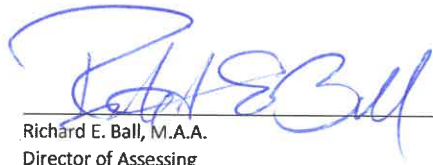

Richard E. Ball, M.A.A.
Director of Assessing

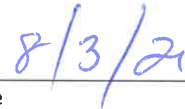

Date

4 parcels/abutters

Appendix G
Abutter Notification Letter and Certified Mail Receipts



Notification to Abutters Under the Massachusetts Wetlands Protection Act

In accordance with the second paragraph of Massachusetts General Laws Chapter 131, Section 40, you are hereby notified of the following:

A. The name of the applicant is: Town of Ashland on behalf of the Massachusetts Department of Fish and Game Office of Fishing and Boating Access.

B. The applicant has filed a Notice of Intent with the Conservation Commission for the Town of Ashland seeking permission to remove, fill, dredge or alter an Area Subject to Protection Under the Wetlands Protection Act (General Laws Chapter 131, Section 40).

Project Description: Aikens Road is a dirt/gravel road that runs parallel to the Sudbury River. Most of the riverfront area between Aikens Road and the Sudbury River consists of undeveloped woodlands. The general public usually accesses the river through these woodlands to fish and engage in other recreational activities. The Town of Ashland in conjunction with the Massachusetts Department of Fish & Game Office of Fishing & Boating Access wishes to formalize access to the river so that the general public can fish and access the river more easily. A formalized fishing area, kayak/canoe launch, and designated parking area is proposed for this project. These areas will consist of crushed stone and poured concrete access ways and ramps, with no raised constructed pier. Impacts to resource areas will be minimal and restored to match existing conditions.

C. The address of the lot where the activity is proposed is: 0 Rock Street (Abandoned), also identified as Aikens Road, Ashland, MA 01721

D. Copies of the Notice of Intent may be examined at the Ashland Conservation Office – 101 Main Street 2nd Floor, Ashland, MA 01721; Monday-Thursday 8:00AM-3:30PM. For more information call 508-881-0100 x7924.

E. Copies of the Notice of Intent may be obtained from the applicant's representative by calling 800-725-2550 x305 between 8:00 am and 5:00 pm, Monday through Friday.

F. Information regarding the date, time and place of the public hearing may be obtained from the Ashland Conservation Commission by calling 508-881-0100 x7924.

NOTE: Notice of the public hearing, including its date, time and place will be published at least five (5) days in advance in The MetroWest Daily News.

NOTE: You also may contact your local Conservation Commission or the nearest Department of Environmental Protection Regional Office for more information about this application or the Wetlands Protection Act. To contact DEP call:

Central Region: (508) 792-7650
Southeast Region: (508) 946-2800

Northeast Region: (978) 661-7600
Western Region: (413) 784-1100

7021 2720 0000 8188 8534

U.S. Postal Service™ CERTIFIED MAIL® RECEIPT

Domestic Mail Only

For delivery information, visit our website at www.usps.com®.

Ashtand, MA 01721

Certified Mail Fee	\$3.75
Extra Services & Fees (check box, add fee as appropriate)	\$3.05
<input type="checkbox"/> Return Receipt (hardcopy)	\$0.00
<input type="checkbox"/> Return Receipt (electronic)	\$0.00
<input type="checkbox"/> Certified Mail Restricted Delivery	\$0.00
<input type="checkbox"/> Adult Signature Required	\$0.00
<input type="checkbox"/> Adult Signature Restricted Delivery	\$0.00

Postage	\$0.58
Total Postage and Fees	\$7.38

0775
04

Postmark
Here

03/15/2022

Sent To Ann Crowley
 Street and Apt. No., or PO Box No. P.O. Box 284
 City, State, ZIP+4® Ashtand, MA 01721

7021 2720 0000 8188 8538

U.S. Postal Service™ CERTIFIED MAIL® RECEIPT

Domestic Mail Only

For delivery information, visit our website at www.usps.com®.

Boston, MA 02114

Certified Mail Fee	\$3.75
Extra Services & Fees (check box, add fee as appropriate)	\$3.05
<input type="checkbox"/> Return Receipt (hardcopy)	\$0.00
<input type="checkbox"/> Return Receipt (electronic)	\$0.00
<input type="checkbox"/> Certified Mail Restricted Delivery	\$0.00
<input type="checkbox"/> Adult Signature Required	\$0.00
<input type="checkbox"/> Adult Signature Restricted Delivery	\$0.00

Postage	\$0.58
Total Postage and Fees	\$7.38

0775
04

Postmark
Here

03/15/2022

Sent To Dept. of Environmental Management
 Street and Apt. No., or PO Box No. 251 Causeway St. Suite 600-700
 City, State, ZIP+4® Boston, MA 02114

Appendix H Stormwater Report Checklist





Checklist for Stormwater Report

A. Introduction

Important: When filling out forms on the computer, use only the tab key to move your cursor - do not use the return key.

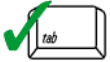

A Stormwater Report must be submitted with the Notice of Intent permit application to document compliance with the Stormwater Management Standards. The following checklist is NOT a substitute for the Stormwater Report (which should provide more substantive and detailed information) but is offered here as a tool to help the applicant organize their Stormwater Management documentation for their Report and for the reviewer to assess this information in a consistent format. As noted in the Checklist, the Stormwater Report must contain the engineering computations and supporting information set forth in Volume 3 of the [Massachusetts Stormwater Handbook](#). The Stormwater Report must be prepared and certified by a Registered Professional Engineer (RPE) licensed in the Commonwealth.

The Stormwater Report must include:

- The Stormwater Checklist completed and stamped by a Registered Professional Engineer (see page 2) that certifies that the Stormwater Report contains all required submittals.¹ This Checklist is to be used as the cover for the completed Stormwater Report.
- Applicant/Project Name
- Project Address
- Name of Firm and Registered Professional Engineer that prepared the Report
- Long-Term Pollution Prevention Plan required by Standards 4-6
- Construction Period Pollution Prevention and Erosion and Sedimentation Control Plan required by Standard 8²
- Operation and Maintenance Plan required by Standard 9

In addition to all plans and supporting information, the Stormwater Report must include a brief narrative describing stormwater management practices, including environmentally sensitive site design and LID techniques, along with a diagram depicting runoff through the proposed BMP treatment train. Plans are required to show existing and proposed conditions, identify all wetland resource areas, NRCS soil types, critical areas, Land Uses with Higher Potential Pollutant Loads (LUHPPL), and any areas on the site where infiltration rate is greater than 2.4 inches per hour. The Plans shall identify the drainage areas for both existing and proposed conditions at a scale that enables verification of supporting calculations.

As noted in the Checklist, the Stormwater Management Report shall document compliance with each of the Stormwater Management Standards as provided in the Massachusetts Stormwater Handbook. The soils evaluation and calculations shall be done using the methodologies set forth in Volume 3 of the Massachusetts Stormwater Handbook.

To ensure that the Stormwater Report is complete, applicants are required to fill in the Stormwater Report Checklist by checking the box to indicate that the specified information has been included in the Stormwater Report. If any of the information specified in the checklist has not been submitted, the applicant must provide an explanation. The completed Stormwater Report Checklist and Certification must be submitted with the Stormwater Report.

¹ The Stormwater Report may also include the Illicit Discharge Compliance Statement required by Standard 10. If not included in the Stormwater Report, the Illicit Discharge Compliance Statement must be submitted prior to the discharge of stormwater runoff to the post-construction best management practices.

² For some complex projects, it may not be possible to include the Construction Period Erosion and Sedimentation Control Plan in the Stormwater Report. In that event, the issuing authority has the discretion to issue an Order of Conditions that approves the project and includes a condition requiring the proponent to submit the Construction Period Erosion and Sedimentation Control Plan before commencing any land disturbance activity on the site.



Checklist for Stormwater Report

B. Stormwater Checklist and Certification

The following checklist is intended to serve as a guide for applicants as to the elements that ordinarily need to be addressed in a complete Stormwater Report. The checklist is also intended to provide conservation commissions and other reviewing authorities with a summary of the components necessary for a comprehensive Stormwater Report that addresses the ten Stormwater Standards.

Note: Because stormwater requirements vary from project to project, it is possible that a complete Stormwater Report may not include information on some of the subjects specified in the Checklist. If it is determined that a specific item does not apply to the project under review, please note that the item is not applicable (N.A.) and provide the reasons for that determination.

A complete checklist must include the Certification set forth below signed by the Registered Professional Engineer who prepared the Stormwater Report.

Registered Professional Engineer's Certification

I have reviewed the Stormwater Report, including the soil evaluation, computations, Long-term Pollution Prevention Plan, the Construction Period Erosion and Sedimentation Control Plan (if included), the Long-term Post-Construction Operation and Maintenance Plan, the Illicit Discharge Compliance Statement (if included) and the plans showing the stormwater management system, and have determined that they have been prepared in accordance with the requirements of the Stormwater Management Standards as further elaborated by the Massachusetts Stormwater Handbook. I have also determined that the information presented in the Stormwater Checklist is accurate and that the information presented in the Stormwater Report accurately reflects conditions at the site as of the date of this permit application.

Registered Professional Engineer Block and Signature



Matthew Lundsted 2/2/22

Signature and Date

Checklist

Project Type: Is the application for new development, redevelopment, or a mix of new and redevelopment?

- New development
- Redevelopment
- Mix of New Development and Redevelopment



Checklist for Stormwater Report

Checklist (continued)

LID Measures: Stormwater Standards require LID measures to be considered. Document what environmentally sensitive design and LID Techniques were considered during the planning and design of the project:

- No disturbance to any Wetland Resource Areas
- Site Design Practices (e.g. clustered development, reduced frontage setbacks)
- Reduced Impervious Area (Redevelopment Only)
- Minimizing disturbance to existing trees and shrubs
- LID Site Design Credit Requested:
 - Credit 1
 - Credit 2
 - Credit 3
- Use of “country drainage” versus curb and gutter conveyance and pipe
- Bioretention Cells (includes Rain Gardens)
- Constructed Stormwater Wetlands (includes Gravel Wetlands designs)
- Treebox Filter
- Water Quality Swale
- Grass Channel
- Green Roof
- Other (describe): River Access Facility

Standard 1: No New Untreated Discharges

- No new untreated discharges
- Outlets have been designed so there is no erosion or scour to wetlands and waters of the Commonwealth
- Supporting calculations specified in Volume 3 of the Massachusetts Stormwater Handbook included.



Checklist for Stormwater Report

Checklist (continued)

Standard 2: Peak Rate Attenuation

- Standard 2 waiver requested because the project is located in land subject to coastal storm flowage and stormwater discharge is to a wetland subject to coastal flooding.
- Evaluation provided to determine whether off-site flooding increases during the 100-year 24-hour storm.
- Calculations provided to show that post-development peak discharge rates do not exceed pre-development rates for the 2-year and 10-year 24-hour storms. If evaluation shows that off-site flooding increases during the 100-year 24-hour storm, calculations are also provided to show that post-development peak discharge rates do not exceed pre-development rates for the 100-year 24-hour storm.

Standard 3: Recharge

- Soil Analysis provided.
- Required Recharge Volume calculation provided.
- Required Recharge volume reduced through use of the LID site Design Credits.
- Sizing the infiltration, BMPs is based on the following method: Check the method used.
 - Static
 - Simple Dynamic
 - Dynamic Field¹
- Runoff from all impervious areas at the site discharging to the infiltration BMP.
- Runoff from all impervious areas at the site is *not* discharging to the infiltration BMP and calculations are provided showing that the drainage area contributing runoff to the infiltration BMPs is sufficient to generate the required recharge volume.
- Recharge BMPs have been sized to infiltrate the Required Recharge Volume.
- Recharge BMPs have been sized to infiltrate the Required Recharge Volume *only* to the maximum extent practicable for the following reason:
 - Site is comprised solely of C and D soils and/or bedrock at the land surface
 - M.G.L. c. 21E sites pursuant to 310 CMR 40.0000
 - Solid Waste Landfill pursuant to 310 CMR 19.000
 - Project is otherwise subject to Stormwater Management Standards only to the maximum extent practicable.
- Calculations showing that the infiltration BMPs will drain in 72 hours are provided.
- Property includes a M.G.L. c. 21E site or a solid waste landfill and a mounding analysis is included.

¹ 80% TSS removal is required prior to discharge to infiltration BMP if Dynamic Field method is used.



Checklist for Stormwater Report

Checklist (continued)

Standard 3: Recharge (continued)

- The infiltration BMP is used to attenuate peak flows during storms greater than or equal to the 10-year 24-hour storm and separation to seasonal high groundwater is less than 4 feet and a mounding analysis is provided.
- Documentation is provided showing that infiltration BMPs do not adversely impact nearby wetland resource areas.

Standard 4: Water Quality

The Long-Term Pollution Prevention Plan typically includes the following:

- Good housekeeping practices;
 - Provisions for storing materials and waste products inside or under cover;
 - Vehicle washing controls;
 - Requirements for routine inspections and maintenance of stormwater BMPs;
 - Spill prevention and response plans;
 - Provisions for maintenance of lawns, gardens, and other landscaped areas;
 - Requirements for storage and use of fertilizers, herbicides, and pesticides;
 - Pet waste management provisions;
 - Provisions for operation and management of septic systems;
 - Provisions for solid waste management;
 - Snow disposal and plowing plans relative to Wetland Resource Areas;
 - Winter Road Salt and/or Sand Use and Storage restrictions;
 - Street sweeping schedules;
 - Provisions for prevention of illicit discharges to the stormwater management system;
 - Documentation that Stormwater BMPs are designed to provide for shutdown and containment in the event of a spill or discharges to or near critical areas or from LUHPPL;
 - Training for staff or personnel involved with implementing Long-Term Pollution Prevention Plan;
 - List of Emergency contacts for implementing Long-Term Pollution Prevention Plan.
- A Long-Term Pollution Prevention Plan is attached to Stormwater Report and is included as an attachment to the Wetlands Notice of Intent.
 - Treatment BMPs subject to the 44% TSS removal pretreatment requirement and the one inch rule for calculating the water quality volume are included, and discharge:
 - is within the Zone II or Interim Wellhead Protection Area
 - is near or to other critical areas
 - is within soils with a rapid infiltration rate (greater than 2.4 inches per hour)
 - involves runoff from land uses with higher potential pollutant loads.
 - The Required Water Quality Volume is reduced through use of the LID site Design Credits.
 - Calculations documenting that the treatment train meets the 80% TSS removal requirement and, if applicable, the 44% TSS removal pretreatment requirement, are provided.



Checklist for Stormwater Report

Checklist (continued)

Standard 4: Water Quality (continued)

- The BMP is sized (and calculations provided) based on:
 - The ½" or 1" Water Quality Volume or
 - The equivalent flow rate associated with the Water Quality Volume and documentation is provided showing that the BMP treats the required water quality volume.
- The applicant proposes to use proprietary BMPs, and documentation supporting use of proprietary BMP and proposed TSS removal rate is provided. This documentation may be in the form of the propriety BMP checklist found in Volume 2, Chapter 4 of the Massachusetts Stormwater Handbook and submitting copies of the TARP Report, STEP Report, and/or other third party studies verifying performance of the proprietary BMPs.
- A TMDL exists that indicates a need to reduce pollutants other than TSS and documentation showing that the BMPs selected are consistent with the TMDL is provided.

Standard 5: Land Uses With Higher Potential Pollutant Loads (LUHPPLs)

- The NPDES Multi-Sector General Permit covers the land use and the Stormwater Pollution Prevention Plan (SWPPP) has been included with the Stormwater Report.
- The NPDES Multi-Sector General Permit covers the land use and the SWPPP will be submitted **prior to** the discharge of stormwater to the post-construction stormwater BMPs.
- The NPDES Multi-Sector General Permit does **not** cover the land use.
- LUHPPLs are located at the site and industry specific source control and pollution prevention measures have been proposed to reduce or eliminate the exposure of LUHPPLs to rain, snow, snow melt and runoff, and been included in the long term Pollution Prevention Plan.
- All exposure has been eliminated.
- All exposure has **not** been eliminated and all BMPs selected are on MassDEP LUHPPL list.
- The LUHPPL has the potential to generate runoff with moderate to higher concentrations of oil and grease (e.g. all parking lots with >1000 vehicle trips per day) and the treatment train includes an oil grit separator, a filtering bioretention area, a sand filter or equivalent.

Standard 6: Critical Areas

- The discharge is near or to a critical area and the treatment train includes only BMPs that MassDEP has approved for stormwater discharges to or near that particular class of critical area.
- Critical areas and BMPs are identified in the Stormwater Report.



Checklist for Stormwater Report

Checklist (continued)

Standard 7: Redevelopments and Other Projects Subject to the Standards only to the maximum extent practicable

- The project is subject to the Stormwater Management Standards only to the maximum Extent Practicable as a:
 - Limited Project
 - Small Residential Projects: 5-9 single family houses or 5-9 units in a multi-family development provided there is no discharge that may potentially affect a critical area.
 - Small Residential Projects: 2-4 single family houses or 2-4 units in a multi-family development with a discharge to a critical area
 - Marina and/or boatyard provided the hull painting, service and maintenance areas are protected from exposure to rain, snow, snow melt and runoff
 - Bike Path and/or Foot Path
 - Redevelopment Project
 - Redevelopment portion of mix of new and redevelopment.
- Certain standards are not fully met (Standard No. 1, 8, 9, and 10 must always be fully met) and an explanation of why these standards are not met is contained in the Stormwater Report.
- The project involves redevelopment and a description of all measures that have been taken to improve existing conditions is provided in the Stormwater Report. The redevelopment checklist found in Volume 2 Chapter 3 of the Massachusetts Stormwater Handbook may be used to document that the proposed stormwater management system (a) complies with Standards 2, 3 and the pretreatment and structural BMP requirements of Standards 4-6 to the maximum extent practicable and (b) improves existing conditions.

Standard 8: Construction Period Pollution Prevention and Erosion and Sedimentation Control

A Construction Period Pollution Prevention and Erosion and Sedimentation Control Plan must include the following information:

- Narrative;
 - Construction Period Operation and Maintenance Plan;
 - Names of Persons or Entity Responsible for Plan Compliance;
 - Construction Period Pollution Prevention Measures;
 - Erosion and Sedimentation Control Plan Drawings;
 - Detail drawings and specifications for erosion control BMPs, including sizing calculations;
 - Vegetation Planning;
 - Site Development Plan;
 - Construction Sequencing Plan;
 - Sequencing of Erosion and Sedimentation Controls;
 - Operation and Maintenance of Erosion and Sedimentation Controls;
 - Inspection Schedule;
 - Maintenance Schedule;
 - Inspection and Maintenance Log Form.
- A Construction Period Pollution Prevention and Erosion and Sedimentation Control Plan containing the information set forth above has been included in the Stormwater Report.



Checklist for Stormwater Report

Checklist (continued)

Standard 8: Construction Period Pollution Prevention and Erosion and Sedimentation Control (continued)

- The project is highly complex and information is included in the Stormwater Report that explains why it is not possible to submit the Construction Period Pollution Prevention and Erosion and Sedimentation Control Plan with the application. A Construction Period Pollution Prevention and Erosion and Sedimentation Control has **not** been included in the Stormwater Report but will be submitted **before** land disturbance begins.
- The project is **not** covered by a NPDES Construction General Permit.
- The project is covered by a NPDES Construction General Permit and a copy of the SWPPP is in the Stormwater Report.
- The project is covered by a NPDES Construction General Permit but no SWPPP been submitted. The SWPPP will be submitted BEFORE land disturbance begins.

Standard 9: Operation and Maintenance Plan

- The Post Construction Operation and Maintenance Plan is included in the Stormwater Report and includes the following information:
 - Name of the stormwater management system owners;
 - Party responsible for operation and maintenance;
 - Schedule for implementation of routine and non-routine maintenance tasks;
 - Plan showing the location of all stormwater BMPs maintenance access areas;
 - Description and delineation of public safety features;
 - Estimated operation and maintenance budget; and
 - Operation and Maintenance Log Form.
- The responsible party is **not** the owner of the parcel where the BMP is located and the Stormwater Report includes the following submissions:
 - A copy of the legal instrument (deed, homeowner's association, utility trust or other legal entity) that establishes the terms of and legal responsibility for the operation and maintenance of the project site stormwater BMPs;
 - A plan and easement deed that allows site access for the legal entity to operate and maintain BMP functions.

Standard 10: Prohibition of Illicit Discharges

- The Long-Term Pollution Prevention Plan includes measures to prevent illicit discharges;
- An Illicit Discharge Compliance Statement is attached;
- NO Illicit Discharge Compliance Statement is attached but will be submitted **prior to** the discharge of any stormwater to post-construction BMPs.

Appendix I

Flood Storage Calculations (Cut/Fill Analysis)



Cut/Fill Analysis						
Elevation (ft)		Cut (sf)	Fill (sf)	Cut (cf)	Fill (cf)	Net Volume (cf)
230	231	0	91	0	91	91
231	232	8	97	-8	97	89
232	233	2	33	-2	33	31
233	234	8	0	-8	0	-8
234	235	346	0	-346	0	-346
235	236	101	0	-101	0	-101
236	237	0	0	0	0	0
237	238	0	0	0	0	0
238	239	0	1507	0	1507	1507
239	240	0	921	0	921	921
240	241	0	843	0	843	843
241	242	0	0	0	0	0
242	243	101	0	-101	0	-101
243	244	179	0	-179	0	-179
244	245	18	0	-18	0	-18
TOTALS:				-762	3492	2729

Notes:

1. Cut/fill analysis based on CAD delineations of existing vs. proposed contours at each elevation. Delineations measured the difference in area at each elevation between existing and proposed contours (cut and fill areas).
2. Cut/fill volumes calculated by averaging the delineated areas at two adjacent elevations and then multiplying by the overall change in elevation (1 ft).
3. Cut volumes are the sum of excavation resulting from proposed contours and the existing structure volume at each elevation interval
4. Fill volumes are the sum of backfill resulting from proposed contours and the proposed structure volume at each elevation interval

 = Cut/Fill within FEMA 100-year flood zone (elevation 234.0')

Appendix J Permit Plans



OFFICE OF FISHING AND BOATING ACCESS

SUDBURY RIVER ACCESS FACILITY

ASHLAND, MA

APRIL 2022

CLIENT REPRESENTATIVES

DOUGLAS H. CAMERON – DIRECTOR – OFBA

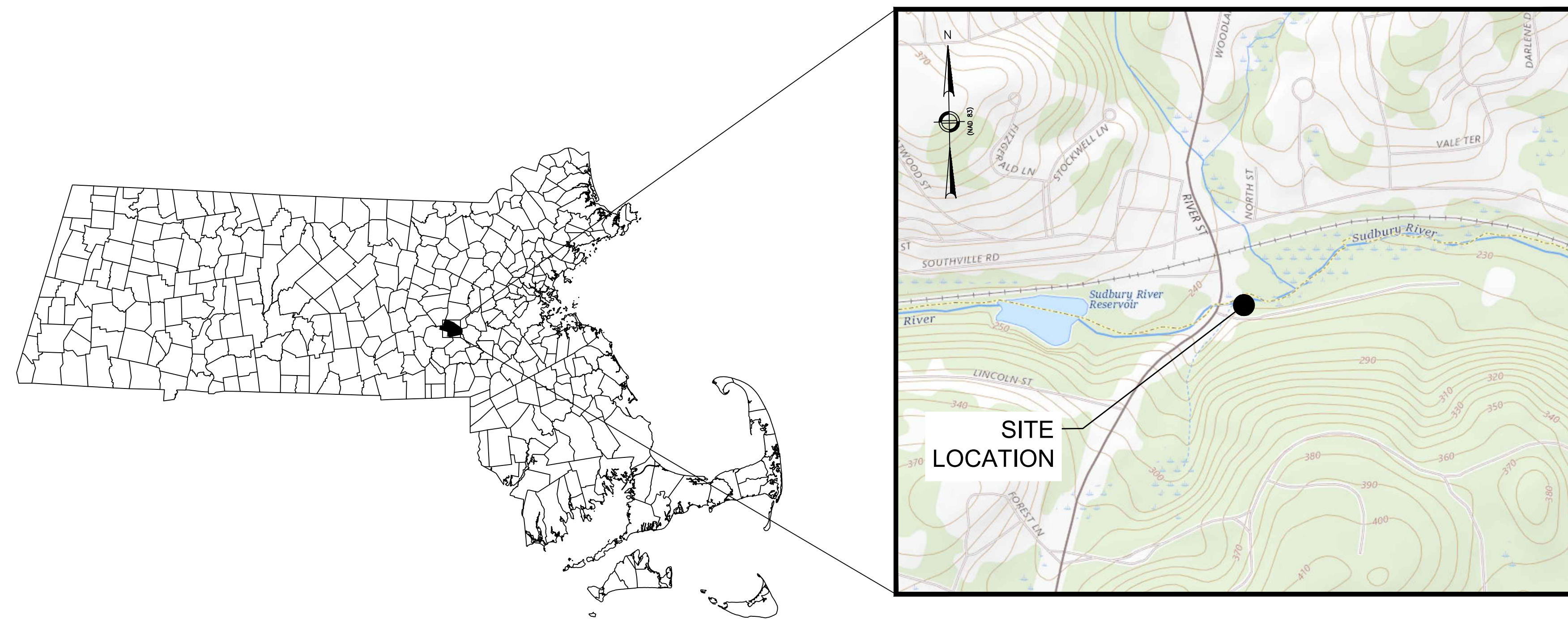

<u>SHEET</u>	<u>TITLE</u>
C-1	EXISTING CONDITIONS
C-2	PROPOSED CONDITIONS
D-1	EROSION CONTROL DETAILS
D-2	DETAILS
P-1	100-YEAR FLOODPLAIN CUT/FILL
P-2	RESOURCE AREA IMPACTS
P-3	25-FOOT NO DISTURB IMPACTS



COMPREHENSIVE ENVIRONMENTAL INCORPORATED

• BOLTON, MASSACHUSETTS

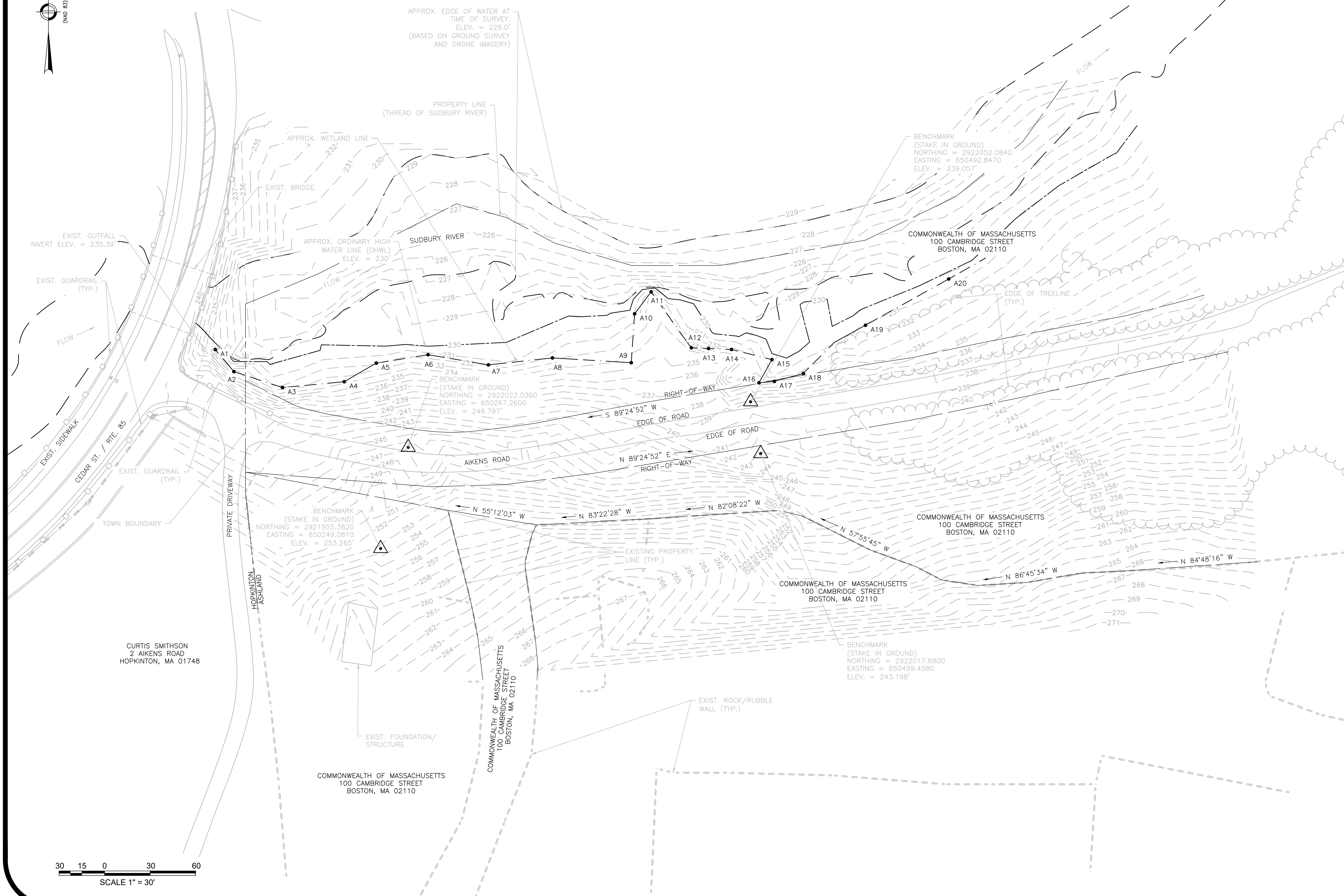
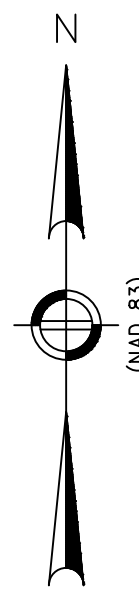

GENERAL NOTES

- SURVEY WAS PERFORMED BY CEI ON 3/11/21 AND 3/12/21

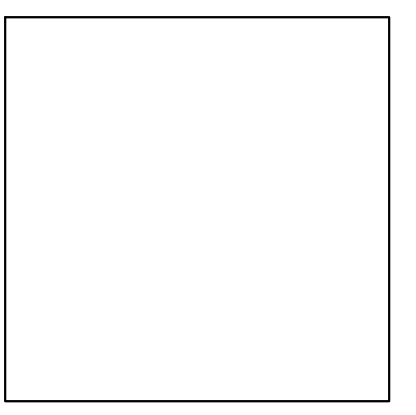

P.E. STAMP

No.	Revision/Issue	Date

COMPREHENSIVE ENVIRONMENTAL INCORPORATED

41 MAIN ST.
BOLTON, MA 01740

**EXISTING CONDITIONS
PLAN VIEW**

Town of Ashland, MA

Project No.: 346-4	Sheet
Date: 3/16/2021	C-1
Drawn By: NBS	
Checked By: MLL	
Scale: AS SHOWN	

CURTIS SMITHSON
2 AIKENS ROAD
HOPKINTON, MA 01748

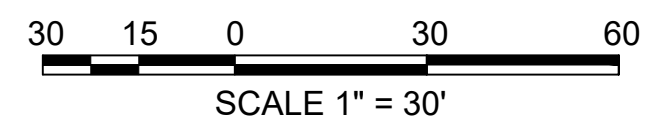

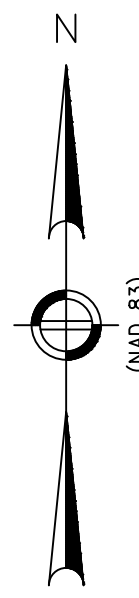

AREAS DISTURBED DURING CONSTRUCTION SHALL BE RESTORED USING LOAM AND SPECIFIED SEED MIXES (SEE PLANTING SCHEDULE DETAIL)

2:1 SLOPES TO BE STABILIZED WITH EXISTING BOULDERS ON SITE.

APPROX. EDGE OF WATER AT TIME OF SURVEY. ELEV. = 229.0' (BASED ON GROUND SURVEY AND DRONE IMAGERY)

SILT BOOM/TURBIDITY CURTAIN (SEE DETAILS)

PROPOSED FISHING AREA. PERIMETER TO BE LINED WITH GRANITE CURBING. (SEE DETAILS)

6' WIDE ACCESS PATH FOR KAYAK/CANOE LAUNCH (SEE DETAILS)

6' WIDE PRECAST CONCRETE PAD FOR KAYAK/CANOE LAUNCH (SEE DETAILS)

BENCHMARK (STAKE IN GROUND) NORTHING = 2922052.0840 EASTING = 650492.8470 ELEV. = 239.057'

PROPOSED GRAVEL PARKING AREA WITH FIVE (5) 8' WIDE x 23' LONG PARKING SPOTS

COMMONWEALTH OF MASSACHUSETTS 100 CAMBRIDGE STREET BOSTON, MA 02110

APPROX. ORDINARY HIGH WATER LINE (OHWL) ELEV. = 230'

PROPERTY LINE (THREAD OF SUDBURY RIVER)

APPROX. WETLAND LINE

EXIST. BRIDGE

SUDBURY RIVER

EDGE OF TREELINE (TYP.)

EXIST. OUTFALL INVERT ELEV. = 235.39'

EXIST. GUARDRAIL (TYP.)

FLOW

FLOW

FLOW

FLOW

EXIST. SIDEWALK

CEEDAR ST. / RTE. 85

EXIST. GUARDRAIL (TYP.)

TOWN BOUNDARY

PRIVATE DRIVEWAY

HOPKINTON ASHLAND

CURTIS SMITHSON
2 AIKENS ROAD
HOPKINTON, MA 01748

BENCHMARK (STAKE IN GROUND) NORTHING = 2921955.3820 EASTING = 650249.0810 ELEV. = 253.265'

N 55°12'03" W

N 83°22'22" E

N 89°24'52" E

N 82°08'22" W

N 57°55'45" W

N 86°45'34" W

N 84°48'16" W

S 89°24'52" W

N 89°24'52" E

N 82°08'22" W

N 57°55'45" W

N 86°45'34" W

N 84°48'16" W

N 82°08'22" W

N 57°55'45" W

N 86°45'34" W

N 84°48'16" W

N 82°08'22" W

N 57°55'45" W

N 86°45'34" W

N 84°48'16" W

N 82°08'22" W

N 57°55'45" W

N 86°45'34" W

N 84°48'16" W

N 82°08'22" W

N 57°55'45" W

N 86°45'34" W

N 84°48'16" W

N 82°08'22" W

N 57°55'45" W

N 86°45'34" W

N 84°48'16" W

N 82°08'22" W

N 57°55'45" W

N 86°45'34" W

N 84°48'16" W

N 82°08'22" W

N 57°55'45" W

N 86°45'34" W

N 84°48'16" W

N 82°08'22" W

N 57°55'45" W

N 86°45'34" W

N 84°48'16" W

N 82°08'22" W

N 57°55'45" W

N 86°45'34" W

N 84°48'16" W

N 82°08'22" W

N 57°55'45" W

N 86°45'34" W

N 84°48'16" W

N 82°08'22" W

N 57°55'45" W

N 86°45'34" W

N 84°48'16" W

N 82°08'22" W

N 57°55'45" W

N 86°45'34" W

N 84°48'16" W

N 82°08'22" W

N 57°55'45" W

N 86°45'34" W

N 84°48'16" W

N 82°08'22" W

N 57°55'45" W

N 86°45'34" W

N 84°48'16" W

N 82°08'22" W

N 57°55'45" W

N 86°45'34" W

N 84°48'16" W

N 82°08'22" W

N 57°55'45" W

N 86°45'34" W

N 84°48'16" W

N 82°08'22" W

N 57°55'45" W

N 86°45'34" W

N 84°48'16" W

N 82°08'22" W

N 57°55'45" W

N 86°45'34" W

N 84°48'16" W

N 82°08'22" W

N 57°55'45" W

N 86°45'34" W

N 84°48'16" W

N 82°08'22" W

N 57°55'45" W

N 86°45'34" W

N 84°48'16" W

N 82°08'22" W

N 57°55'45" W

N 86°45'34" W

N 84°48'16" W

N 82°08'22" W

N 57°55'45" W

N 86°45'34" W

N 84°48'16" W

N 82°08'22" W

N 57°55'45" W

N 86°45'34" W

N 84°48'16" W

N 82°08'22" W

N 57°55'45" W

N 86°45'34" W

N 84°48'16" W

N 82°08'22" W

N 57°55'45" W

N 86°45'34" W

N 84°48'16" W

N 82°08'22" W

N 57°55'45" W

N 86°45'34" W

N 84°48'16" W

N 82°08'22" W

N 57°55'45" W

N 86°45'34" W

N 84°48'16" W

N 82°08'22" W

N 57°55'45" W

N 86°45'34" W

N 84°48'16" W

N 82°08'22" W

N 57°55'45" W

N 86°45'34" W

N 84°48'16" W

N 82°08'22" W

N 57°55'45" W

N 86°45'34" W

N 84°48'16" W

N 82°08'22" W

N 57°55'45" W

N 86°45'34" W

N 84°48'16" W

N 82°08'22" W

N 57°55'45" W

N 86°45'34" W

N 84°48'16" W

N 82°08'22" W

N 57°55'45" W

N 86°45'34" W

N 84°48'16" W

N 82°08'22" W

N 57°55'45" W

N 86°45'34" W

N 84°48'16" W

N 82°08'22" W

N 57°55'45" W

N 86°45'34" W

N 84°48'16" W

N 82°08'22" W

N 57°55'45" W

N 86°45'34" W

N 84°48'16" W

N 82°08'22" W

N 57°55'45" W

N 86°45'34" W

N 84°48'16" W

N 82°08'22" W

N 57°55'45" W

N 86°45'34" W

N 84°48'16" W

N 82°08'22" W

N 57°55'45" W

N 86°45'34" W

N 84°48'16" W

N 82°08'22" W

N 57°55'45" W

N 86°45'34" W

N 84°48'16" W

N 82°08'22" W

N 57°55'45" W

N 86°45'34" W

N 84°48'16" W

N 82°08'22" W

N 57°55'45" W

N 86°45'34" W

N 84°48'16" W

N 82°08'22" W

N 57°55'45" W

N 86°45'34" W

N 84°48'16" W

N 82°08'22" W

N 57°55'45" W

N 86°45'34" W

N 84°48'16" W

N 82°08'22" W

N 57°55'45" W

N 86°45'34" W

N 84°48'16" W

N 82°08'22" W

N 57°55'45" W

N 86°45'34" W

N 84°48'16" W

N 82°08'22" W

N 57°55'45" W

N 86°45'34" W

N 84°48'16" W

N 82°08'22" W

N 57°55'45" W

N 86°45'34" W

N 84°48'16" W

N 82°08'22" W

N 57°55'45" W

N 86°45'34" W

N 84°48'16" W

N 82°08'22" W

N 57°55'45" W

N 86°45'34" W

N 84°48'16" W

N 82°08'22" W

N 57°55'45" W

N 86°45'34" W

GENERAL NOTES:

1. PROVIDE A MINIMUM TUBE DIAMETER OF 12 INCHES (300mm) FOR SLOPES UP TO 50 FEET (15.24m) IN LENGTH WITH A SLOPE RATIO OF 3H:1V OR STEEPER. LONGER SLOPES OF 3H:1V MAY REQUIRE LARGER TUBE DIAMETER OR ADDITIONAL COURSING OF FILTER TUBES TO CREATE A FILTER BERM. REFER TO MANUFACTURER'S RECOMMENDATIONS FOR SITUATIONS WITH LONGER OR STEEPER SLOPES.
2. INSTALL TUBES ALONG CONTOURS AND PERPENDICULAR TO SHEET OR CONCENTRATED FLOW.
3. TUBE LOCATION MAY BE SHIFTED TO ADJUST TO LANDSCAPE FEATURES, BUT SHALL PROTECT UNDISTURBED AREA AND VEGETATION TO MAXIMUM EXTENT POSSIBLE.
4. DO NOT INSTALL IN PERENNIAL, EPHEMERAL OR INTERMITTENT STREAMS.
5. ADDITIONAL TUBES SHALL BE USED AT THE DIRECTION OF THE ENGINEER.
6. ADDITIONAL STAKING SHALL BE USED AT THE DIRECTION OF THE ENGINEER.

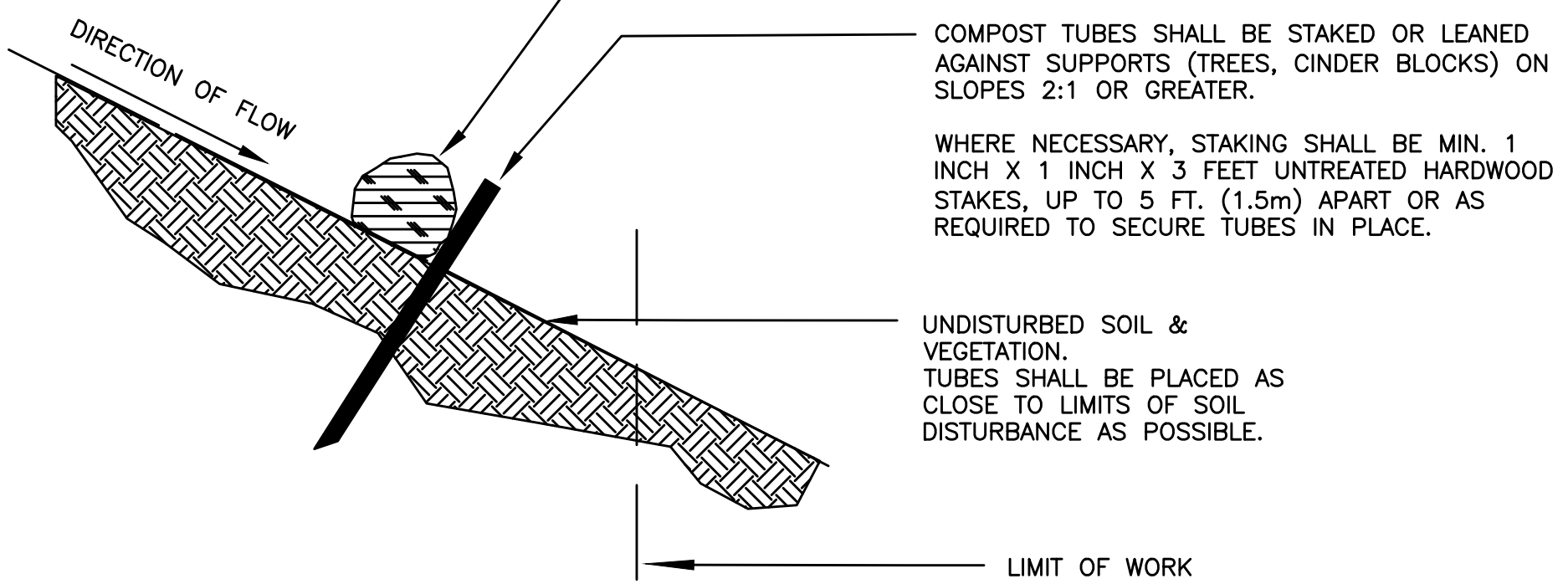

LINEAR SEDIMENTATION AND EROSION CONTROL DETAIL

SCALE: N.T.S.

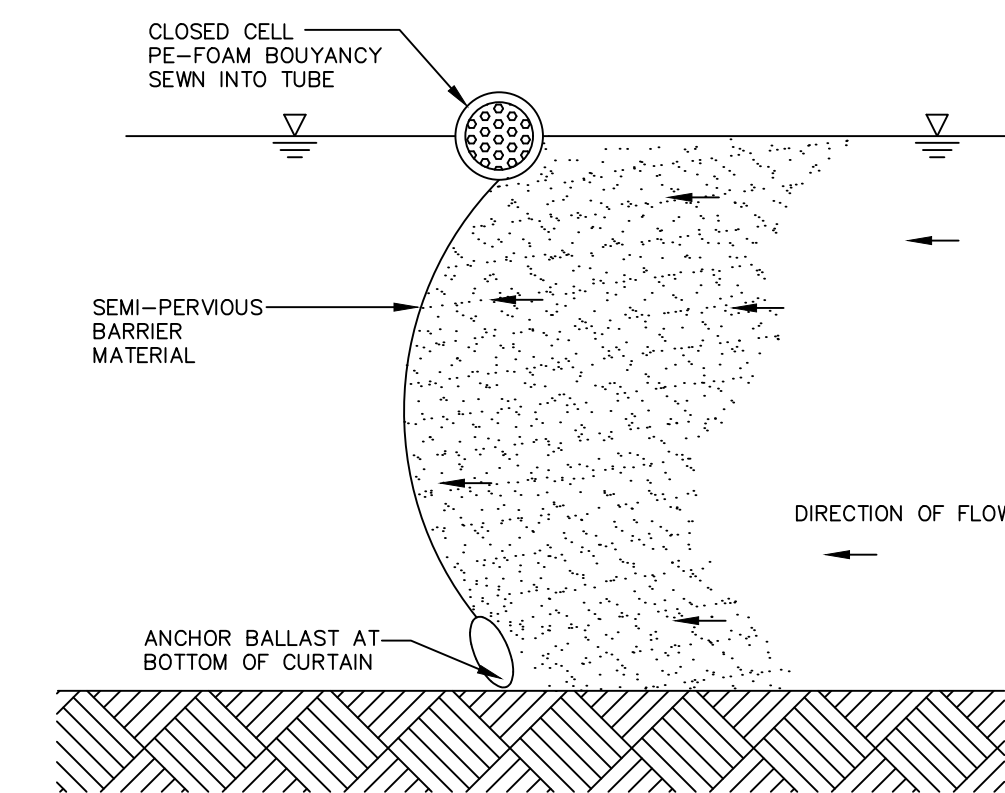
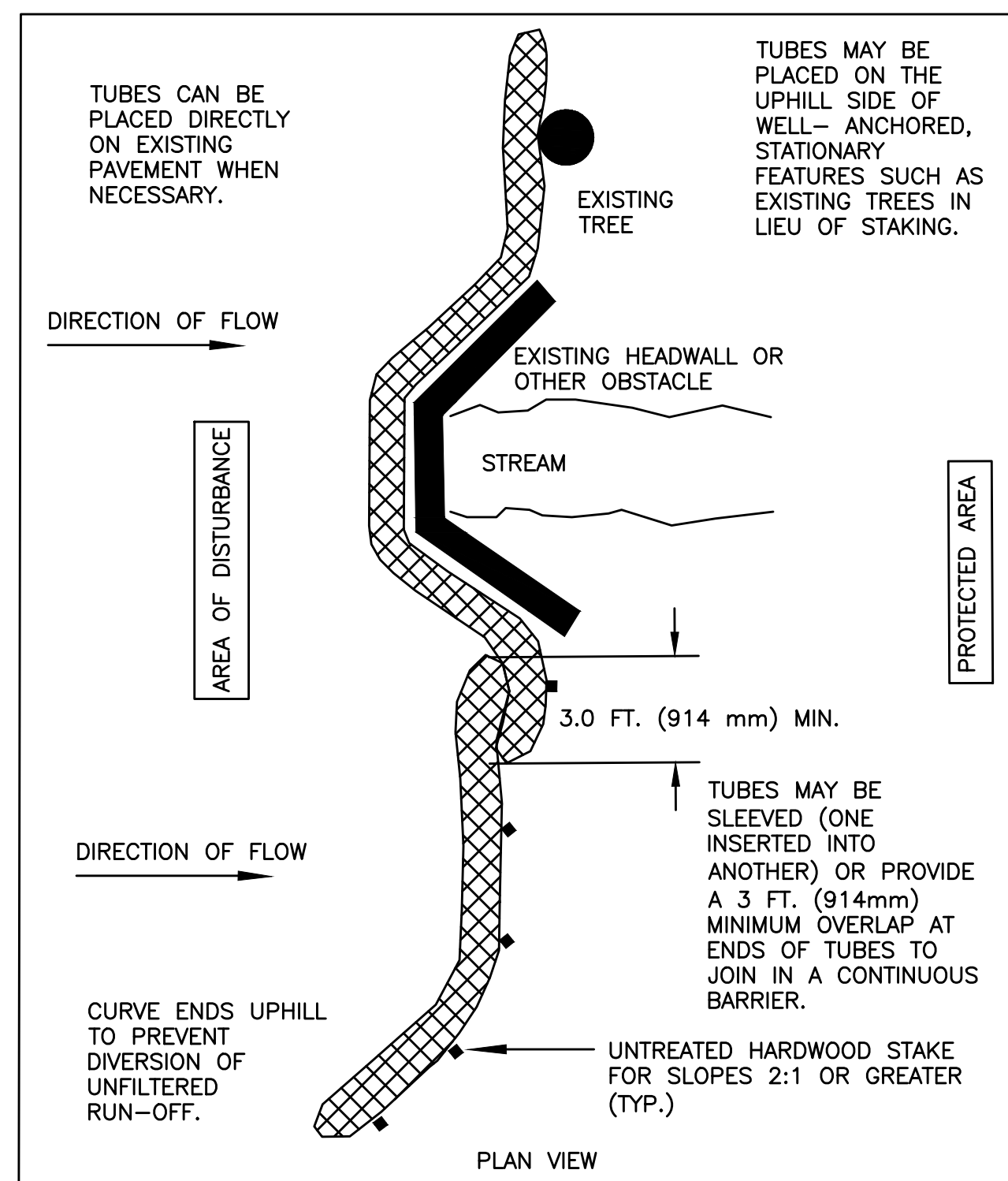

**TURBIDITY CUTAIN FOR SILTATION CONTROL
TYP. DETAIL
SCALE: N.T.S.**

NOTES:

1. CONTRACTOR SHALL SUBMIT FOR REVIEW A PROPOSED TURBIDITY CURTAIN DESIGN PRIOR TO START OF CONSTRUCTION. CURTAIN TO BE DESIGNED AND INSTALLED BY SPECIALISTS WITH EXPERIENCE IN INSTALLING AND MAINTAINING TURBIDITY CURTAINS. CURTAIN DESIGN SHALL ACCOMMODATE, AS A MINIMUM, THE ORDINARY HIGH WATER AND APPROXIMATE NORMAL LOW WATER ELEVATIONS.
2. CONTRACTOR SHALL PROVIDE ADEQUATE ANCHORING TO MAINTAIN THE EFFECTIVENESS OF THE TURBIDITY CURTAIN. IF NECESSARY, USE INTERMEDIATE ANCHOR POSTS FOR ADDITIONAL STABILITY (MAX. SPACING 50' O.C.).
3. TURBIDITY CURTAIN SHALL BE 22 OZ.-500 LB/INCH FASTWATER SCREEN BY ELASTEC/AMERICAN MARINE, CARM, IL, OR APPROVED EQUAL.
4. CONTRACTOR IS RESPONSIBLE FOR LOCATION AND ORIENTATION OF TURBIDITY CURTAIN TO PREVENT MIGRATION OF SILT.
5. CONTRACTOR SHALL INSPECT AND MAINTAIN TURBIDITY CURTAIN AT THE START AND END OF EACH WORK DAY.
6. ONLY AFTER CONSTRUCTION ACTIVITIES ARE COMPLETE AND THE SITE IS STABILIZED SHALL TURBIDITY CURTAIN BE REMOVED.

No.	Revision/Issue	Date

COMPREHENSIVE ENVIRONMENTAL INCORPORATED

41 MAIN ST.
BOLTON, MA 01740

EROSION CONTROL DETAILS

Town of Ashland, MA

Project No.: 346-4 Date: 5/25/2021 Drawn By: NBS Checked By: MLL Scale: AS SHOWN	Sheet D-1
--	---------------------

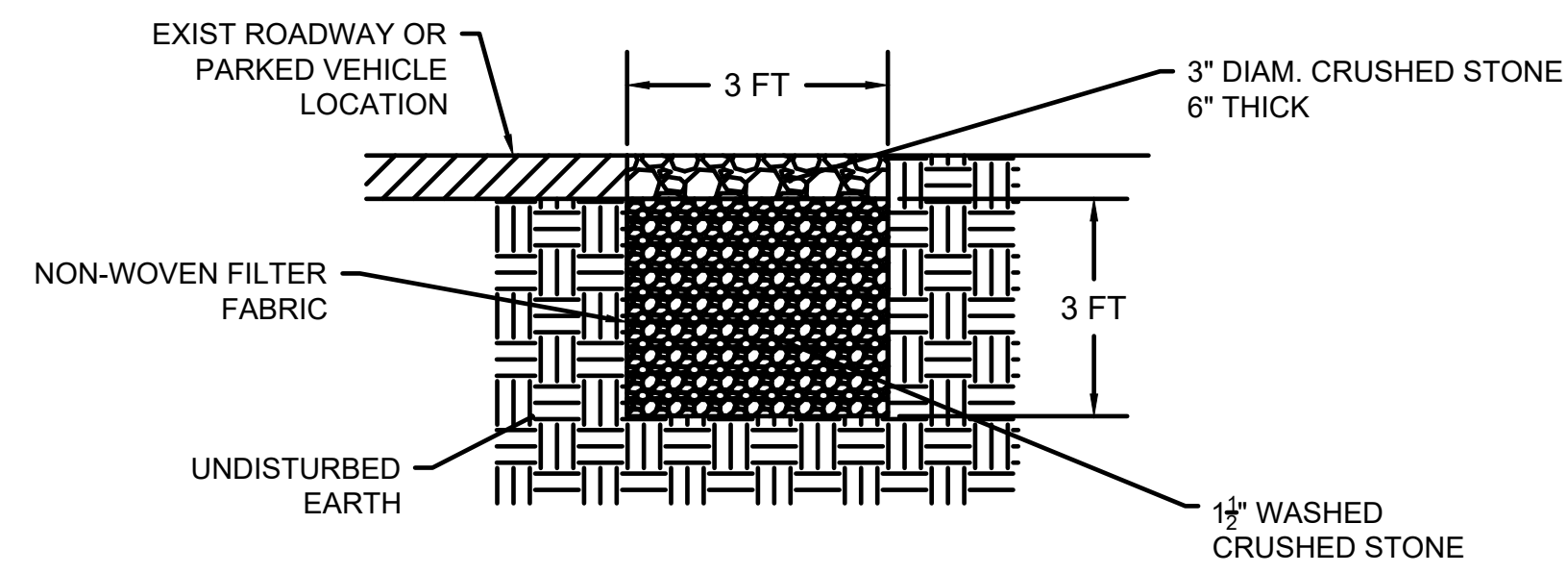

3-FT WIDE INFILTRATION TRENCH DETAIL
N.T.S

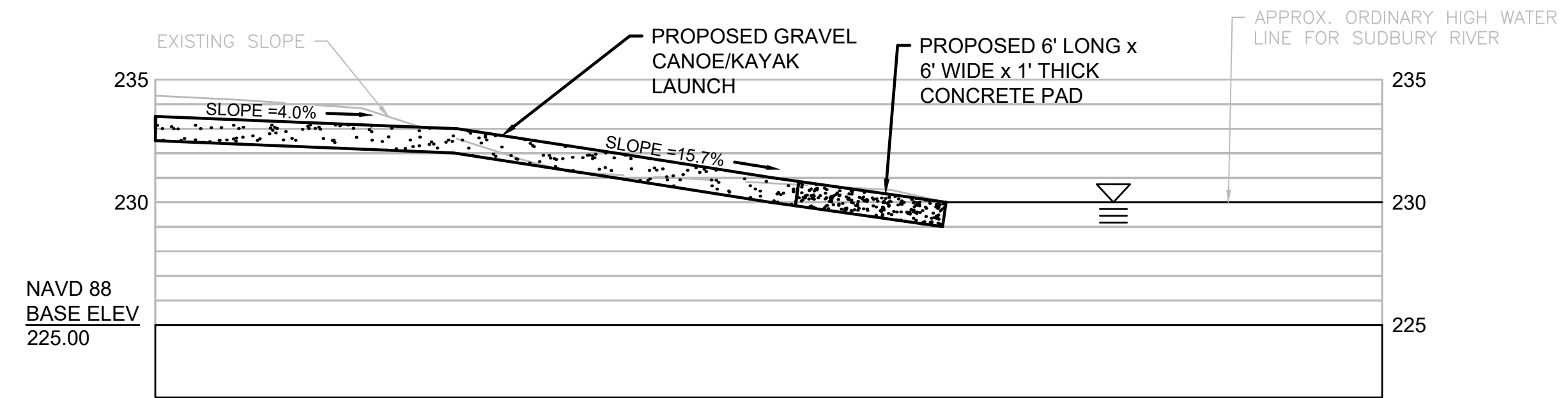

KAYAK/CANOE LAUNCH PROFILE
SCALE: 1"=5'

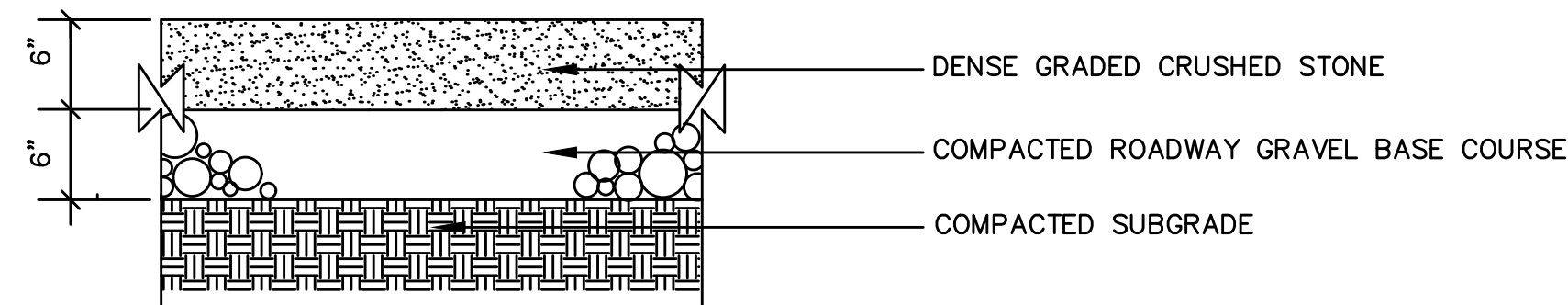

GRAVEL PARKING AREA
SCALE: N.T.S

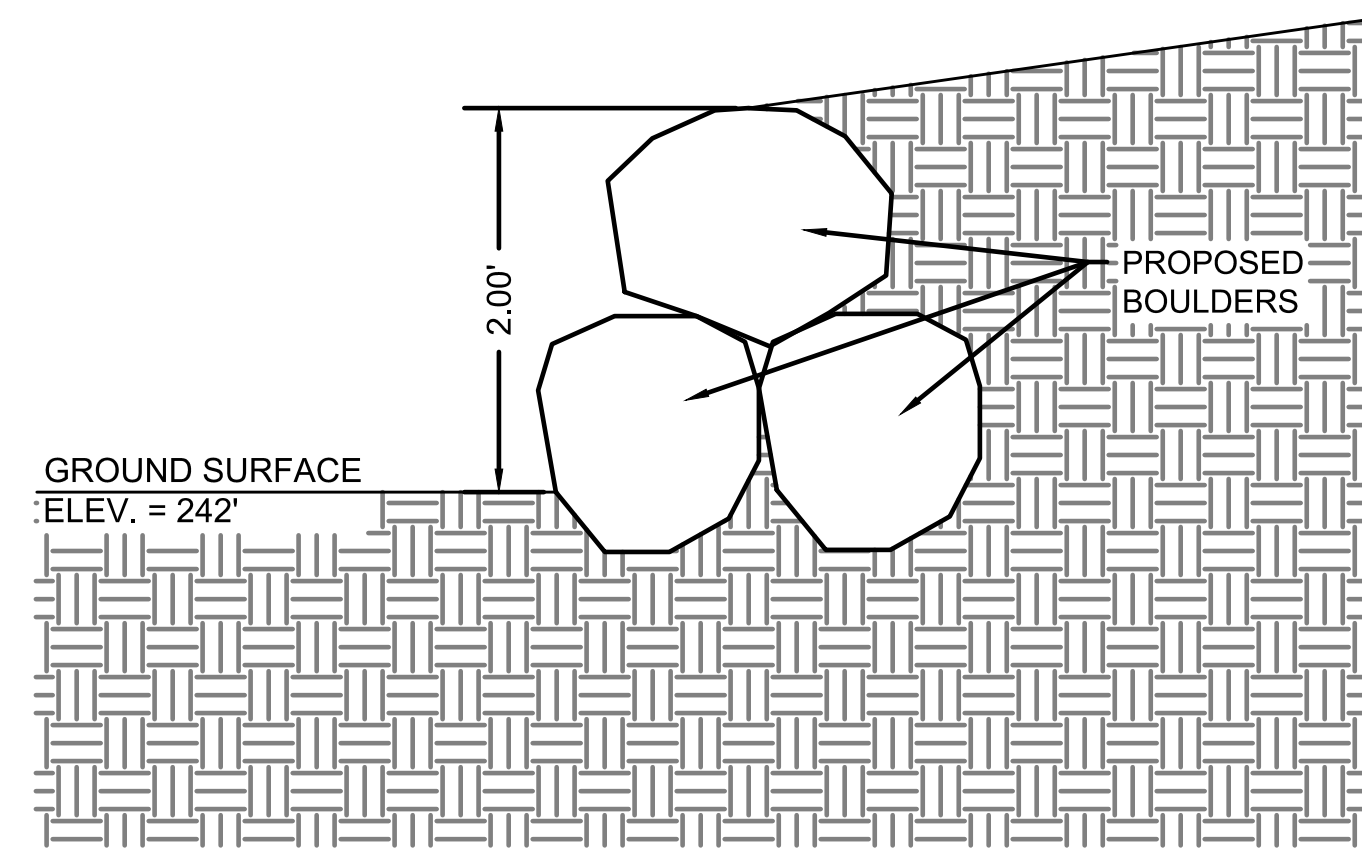

PARKING AREA RETAINING WALL DETAIL
SCALE: 1"=1'

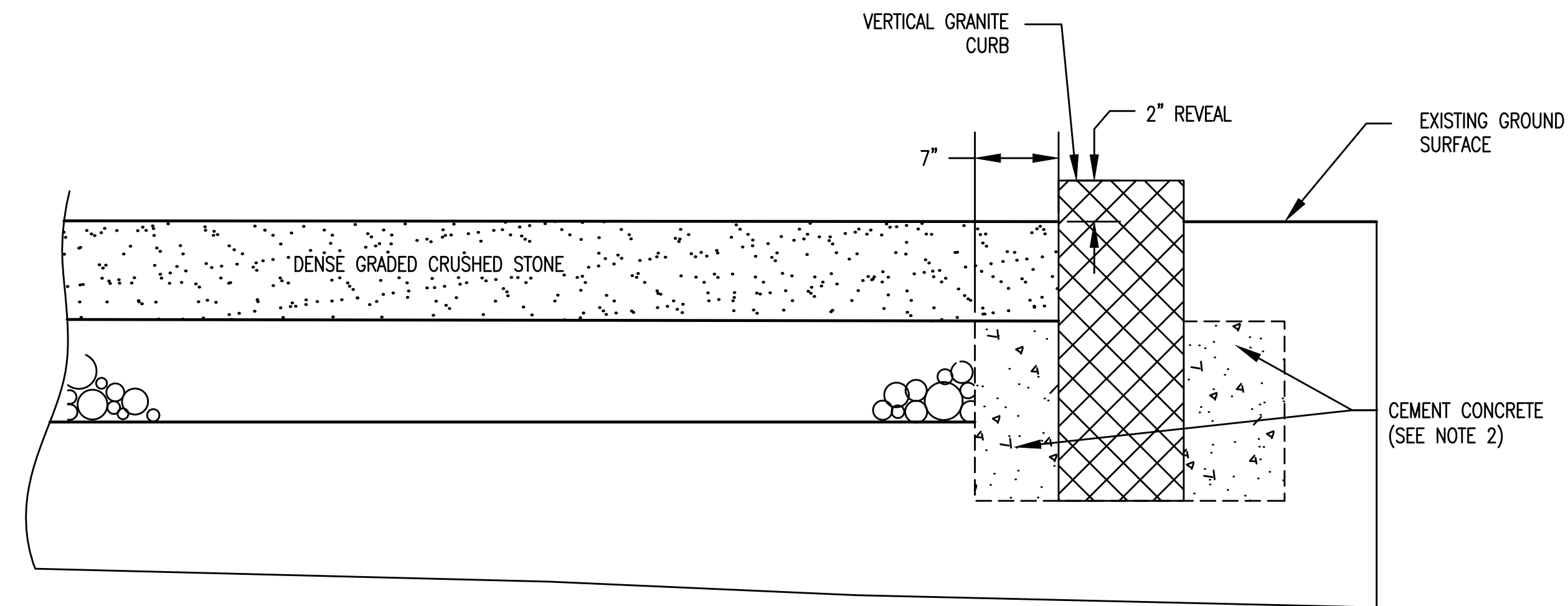

- NOTES:
 1. ANY CLASS CEMENT CONCRETE WILL BE ACCEPTABLE.
 2. CUT STONE TO BE REQUIRED CURVATURE IF SET ON RADIUS OF 100 FT. OR LESS.
 3. MASS. TYPE VA-4 - MIN. LENGTH 6"
 TOP WIDTH 6"
 DEPTH 17"-19"
 MIN. BOT. WIDTH 4"(FOR 2/3 LENGTH)

GRANITE CURB DETAIL
SCALE: N.T.S

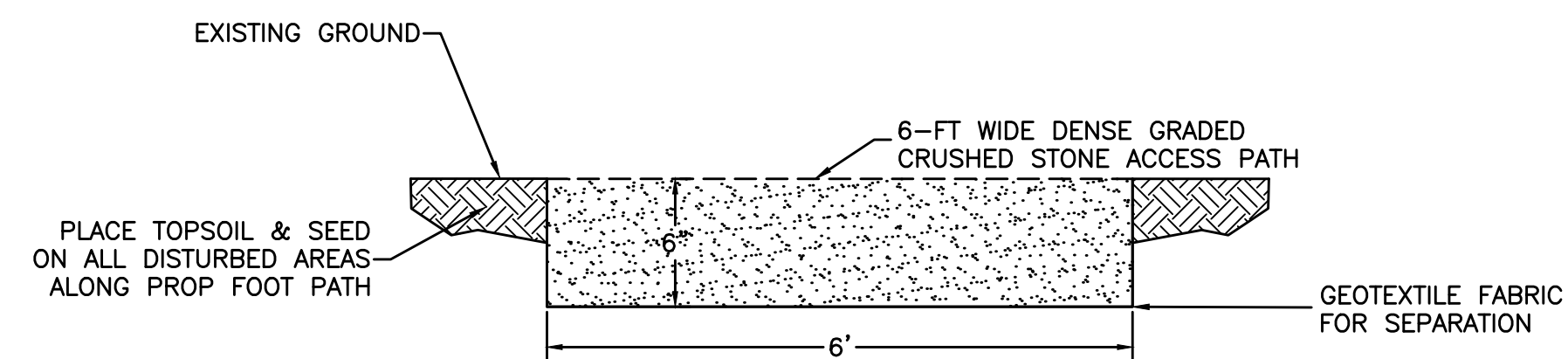

ACCESS PATH
SCALE: N.T.S

PLANTING SCHEDULE		
PLANTING TYPE	SPECIES	PLANTING NOTES
SEED MIXTURE	NEW ENGLAND WETMIX (NEW ENGLAND WETLAND PLANTS, INC.)	SEED MIXTURE APPLIED IN AREAS OF TEMPORARY BORDERING VEGETATED WETLANDS (BVW) IMPACT AT A RATE OF 1 LB./2500 SQ. FT. BVW RESTORATION AREAS ARE TO BE RAKED PRIOR TO SEEDING.
SEED MIXTURE	NEW ENGLAND CONSERVATION / WILDLIFE MIX (NEW ENGLAND WETLAND PLANTS, INC.)	SEED MIXTURE APPLIED IN AREAS OF TEMPORARY BUFFER ZONE IMPACT AT A RATE OF 1 LB./1750 SQ. FT. AREAS ARE TO BE STABILIZED WITH A WEED-FREE STRAW MULCH.

GENERAL NOTES

P.E. STAMP

No.	Revision/Issue	Date

COMPREHENSIVE ENVIRONMENTAL INCORPORATED

41 MAIN ST.
BOLTON, MA 01740

DETAILS

Town of Ashland, MA

Project No.: 346-4	Sheet
Date: 5/25/2021	D-2
Drawn By: NBS	
Checked By: MLL	
Scale: AS SHOWN	

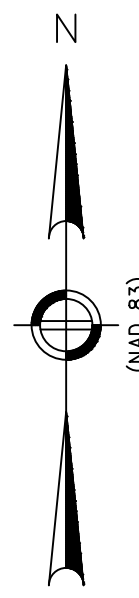

AREAS DISTURBED DURING CONSTRUCTION SHALL BE RESTORED USING LOAM AND SPECIFIED SEED MIXES (SEE PLANTING SCHEDULE DETAIL)

2:1 SLOPES TO BE STABILIZED WITH EXISTING BOULDERS ON SITE.

APPROX. EDGE OF WATER AT TIME OF SURVEY. ELEV. = 229.0' (BASED ON GROUND SURVEY AND DRONE IMAGERY)

SILT BOOM/TURBIDITY CURTAIN (SEE DETAILS)

PROPOSED FISHING AREA. PERIMETER TO BE LINED WITH GRANITE CURBING. (SEE DETAILS)

6' WIDE ACCESS PATH FOR KAYAK/CANOE LAUNCH (SEE DETAILS)

6' WIDE PRECAST CONCRETE PAD FOR KAYAK/CANOE LAUNCH (SEE DETAILS)

PROPOSED GRAVEL PARKING AREA WITH FIVE (5) 8' WIDE x 23' LONG PARKING SPOTS

BENCHMARK (STAKE IN GROUND)
NORTHING = 2922052.0840
EASTING = 650492.8470
ELEV. = 239.057'

COMMONWEALTH OF MASSACHUSETTS
100 CAMBRIDGE STREET
BOSTON, MA 02110

EDGE OF TREETLINE (TYP.)

PROPOSED 3' WIDE INFILTRATION TRENCH (SEE DETAILS)

FEMA 100-YEAR FLOOD ELEV. = 234.0'

MIN. 6' WIDE ACCESS PATH (SEE DETAILS)

PROPOSED LINEAR SEDIMENTATION AND EROSION CONTROLS (SEE DETAILS)

PROPOSED RETAINING WALL (SEE DETAILS)

COMMONWEALTH OF MASSACHUSETTS
100 CAMBRIDGE STREET
BOSTON, MA 02110

LINEAR SEDIMENTATION AND EROSION CONTROLS (SEE DETAILS)

BENCHMARK (STAKE IN GROUND)
NORTHING = 2922017.8900
EASTING = 650499.4580
ELEV. = 243.198'

EXIST. ROCK/RUBBLE WALL (TYP.)

COMMONWEALTH OF MASSACHUSETTS
100 CAMBRIDGE STREET
BOSTON, MA 02110

EXIST. FOUNDATION/STRUCTURE

COMMONWEALTH OF MASSACHUSETTS
100 CAMBRIDGE STREET
BOSTON, MA 02110

CURTIS SMITHSON
2 AIKENS ROAD
HOPKINTON, MA 01748

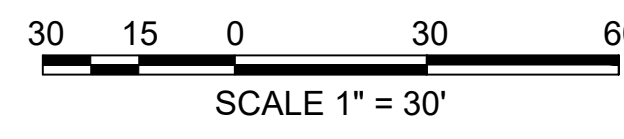

GENERAL NOTES

- FEMA 100-YEAR FLOODPLAIN ELEVATION = 234.0'
- *CUT WITHIN 100-YEAR FLOODPLAIN = 461 CF (AREA = 461 SF)
- *DOES NOT INCLUDE FLOODPLAIN MITIGATION AREA
- FILL WITHIN 100-YEAR FLOODPLAIN = 213 CF (AREA = 213 SF)
- LOCATION OF FLOODPLAIN MITIGATION/COMPENSATORY FLOOD STORAGE = 354 CF (AREA = 354 SF)

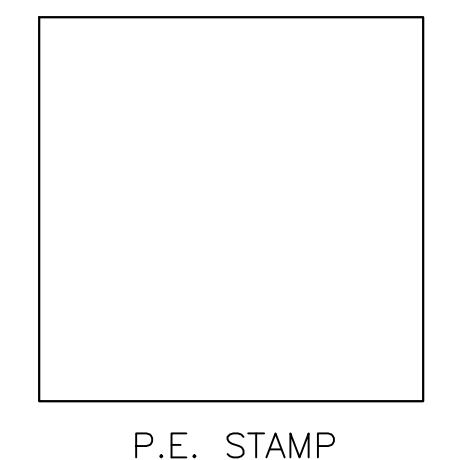

P.E. STAMP

No.	Revision/Issue	Date

COMPREHENSIVE ENVIRONMENTAL INCORPORATED

41 MAIN ST.
BOLTON, MA 01740

100-YEAR FLOOD PLAIN CUT/FILL IMPACTS

Town of Ashland, MA

Project No.: 346-4	Sheet
Date: 5/25/2021	P-1
Drawn By: NBS	
Checked By: MLL	
Scale: AS SHOWN	

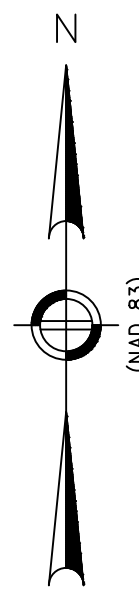

AREAS DISTURBED DURING CONSTRUCTION SHALL BE RESTORED USING LOAM AND SPECIFIED SEED MIXES (SEE PLANTING SCHEDULE DETAIL)

APPROX. EDGE OF WATER AT TIME OF SURVEY. ELEV. = 229.0' (BASED ON GROUND SURVEY AND DRONE IMAGERY)

PROPERTY LINE (THREAD OF SUDBURY RIVER)

2:1 SLOPES TO BE STABILIZED WITH EXISTING BOULDERS ON SITE.

SILT BOOM/TURBIDITY CURTAIN (SEE DETAILS)

PROPOSED FISHING AREA. PERIMETER TO BE LINED WITH GRANITE CURBING (SEE DETAILS)

6' WIDE ACCESS PATH FOR KAYAK/CANOE LAUNCH (SEE DETAILS)

6' WIDE PRECAST CONCRETE PAD FOR KAYAK/CANOE LAUNCH (SEE DETAILS)

BENCHMARK (STAKE IN GROUND)
NORTHING = 2922052.0840
EASTING = 650492.8470
ELEV. = 239.057'

TEMPORARY IMPACTS

- BORDERING VEGETATED WETLAND (653 SF)
- LAND UNDER WATER-BODIES AND WATERWAYS (0 SF)
- BORDERING LAND SUBJECT TO FLOODING (1,900 SF)
- BANK (49 LF)
- 100FT BUFFER ZONE (4,911 SF)
- 200FT RIVERFRONT (4,911 SF)

PERMANENT IMPACTS

- BORDERING VEGETATED WETLAND (0 SF)
- LAND UNDER WATER-BODIES AND WATERWAYS (0 SF)
- BORDERING LAND SUBJECT TO FLOODING (200 SF)
- BANK (12 LF)
- 100FT BUFFER ZONE (4,488 SF)
- 200FT RIVERFRONT (4,488 SF)

PROPOSED ALTERATION

- TOTAL = 653 SF
- TOTAL = 0 SF
- TOTAL = 2,100 SF
- TOTAL = 61 LF
- TOTAL = 9,399 SF
- TOTAL = 9,399 SF

GENERAL NOTES

- FEMA 100-YEAR FLOODPLAIN ELEVATION = 234.0'
- BANK RUNS FROM FLAG A9 TO A12. BVW EVERYWHERE ELSE

P.E. STAMP

No.	Revision/Issue	Date

COMPREHENSIVE ENVIRONMENTAL INCORPORATED



41 MAIN ST.
BOLTON, MA 01740

RESOURCE AREA IMPACTS

Town of Ashland, MA

Project No.: 346-4	Sheet
Date: 5/25/2021	P-2
Drawn By: NBS	
Checked By: MLL	
Scale: AS SHOWN	

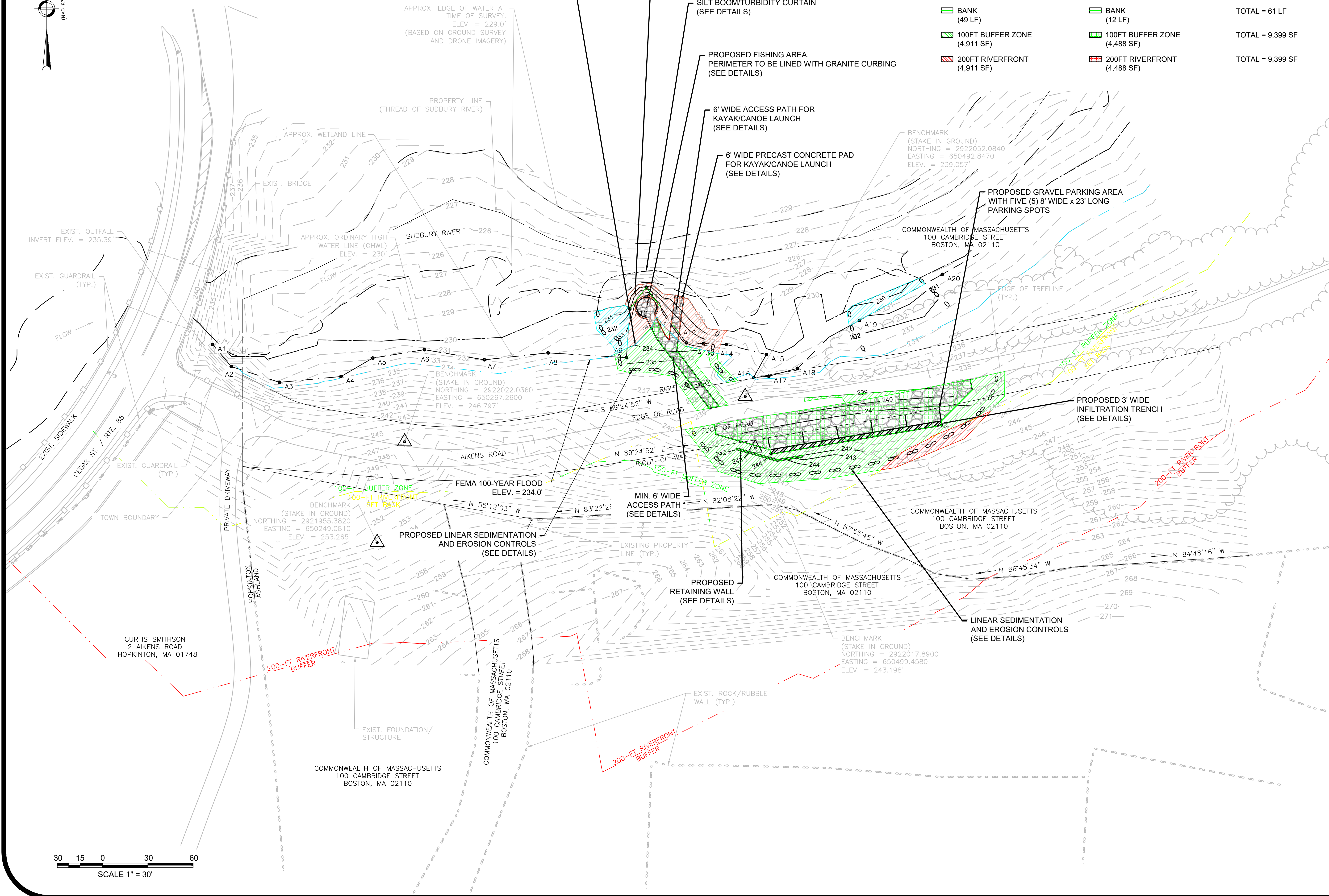

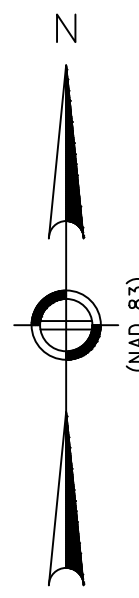

AREAS DISTURBED DURING CONSTRUCTION SHALL BE RESTORED USING LOAM AND SPECIFIED SEED MIXES (SEE PLANTING SCHEDULE DETAIL)

APPROX. EDGE OF WATER AT TIME OF SURVEY. ELEV. = 229.0' (BASED ON GROUND SURVEY AND DRONE IMAGERY)

PROPERTY LINE (THREAD OF SUDBURY RIVER)

APPROX. WETLAND LINE

EXIST. BRIDGE

APPROX. ORDINARY HIGH WATER LINE (OHWL) ELEV. = 230'

SUDBURY RIVER

2:1 SLOPES TO BE STABILIZED WITH EXISTING BOULDERS ON SITE.

SILT BOOM/TURBIDITY CURTAIN (SEE DETAILS)

PROPOSED FISHING AREA. PERIMETER TO BE LINED WITH GRANITE CURBING. (SEE DETAILS)

6' WIDE ACCESS PATH FOR KAYAK/CANOE LAUNCH (SEE DETAILS)

6' WIDE PRECAST CONCRETE PAD FOR KAYAK/CANOE LAUNCH (SEE DETAILS)

BENCHMARK (STAKE IN GROUND) NORTHING = 2922052.0840 EASTING = 650492.8470 ELEV. = 239.057'

PROPOSED GRAVEL PARKING AREA WITH FIVE (5) 8' WIDE x 23' LONG PARKING SPOTS

COMMONWEALTH OF MASSACHUSETTS 100 CAMBRIDGE STREET BOSTON, MA 02110

EDGE OF TREETLINE (TYP.)

EXIST. OUTFALL INVERT ELEV. = 235.39'

EXIST. GUARDRAIL (TYP.)

EXIST. GUARDRAIL (TYP.)

EXIST. GUARDRAIL (TYP.)

EXIST. GUARDRAIL (TYP.)

EXIST. GUARDRAIL (TYP.)

EXIST. GUARDRAIL (TYP.)

EXIST. GUARDRAIL (TYP.)

EXIST. GUARDRAIL (TYP.)

EXIST. GUARDRAIL (TYP.)

EXIST. GUARDRAIL (TYP.)

EXIST. GUARDRAIL (TYP.)

EXIST. GUARDRAIL (TYP.)

EXIST. GUARDRAIL (TYP.)

EXIST. GUARDRAIL (TYP.)

EXIST. GUARDRAIL (TYP.)

25-FT NO-DISTURB BUFFER

FEMA 100-YEAR FLOOD ELEV. = 234.0'

PROPOSED LINEAR SEDIMENTATION AND EROSION CONTROLS (SEE DETAILS)

MIN. 6' WIDE ACCESS PATH (SEE DETAILS)

PROPOSED RETAINING WALL (SEE DETAILS)

PROPOSED 3' WIDE INFILTRATION TRENCH (SEE DETAILS)

COMMONWEALTH OF MASSACHUSETTS 100 CAMBRIDGE STREET BOSTON, MA 02110

COMMONWEALTH OF MASSACHUSETTS 100 CAMBRIDGE STREET BOSTON, MA 02110

LINEAR SEDIMENTATION AND EROSION CONTROLS (SEE DETAILS)

BENCHMARK (STAKE IN GROUND) NORTHING = 2922017.8900 EASTING = 650499.4580 ELEV. = 243.198'

EXIST. ROCK/RUBBLE WALL (TYP.)

COMMONWEALTH OF MASSACHUSETTS 100 CAMBRIDGE STREET BOSTON, MA 02110

EXIST. FOUNDATION/STRUCTURE

COMMONWEALTH OF MASSACHUSETTS 100 CAMBRIDGE STREET BOSTON, MA 02110

CURTIS SMITHSON
2 AIKENS ROAD
HOPKINTON, MA 01748

30 15 0 30 60
SCALE 1" = 30'

TEMPORARY IMPACTS
25-FT NO DISTURB BUFFER (4,235 SF)

PERMANENT IMPACTS
25-FT NO DISTURB BUFFER (756 SF)

PROPOSED ALTERATION
TOTAL = 4,911 SF

GENERAL NOTES

- FEMA 100-YEAR FLOODPLAIN ELEVATION = 234.0'
- BANK RUNS FROM FLAG A9 TO A12. BVV EVERYWHERE ELSE

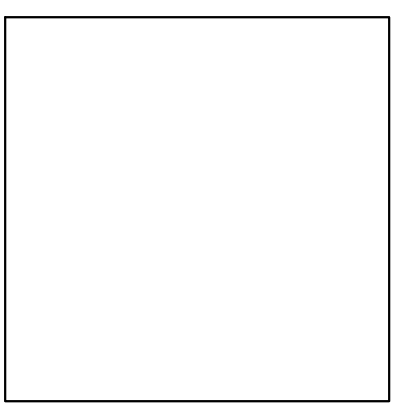

P.E. STAMP

No.	Revision/Issue	Date

COMPREHENSIVE ENVIRONMENTAL INCORPORATED



41 MAIN ST.
BOLTON, MA 01740

25-FOOT NO DISTURB IMPACTS

Town of Ashland, MA

Project No.: 346-4	Sheet
Date: 5/25/2021	P-3
Drawn By: NBS	
Checked By: MLL	
Scale: AS SHOWN	